

CHE

HEAT TRANSFER PRODUCTS

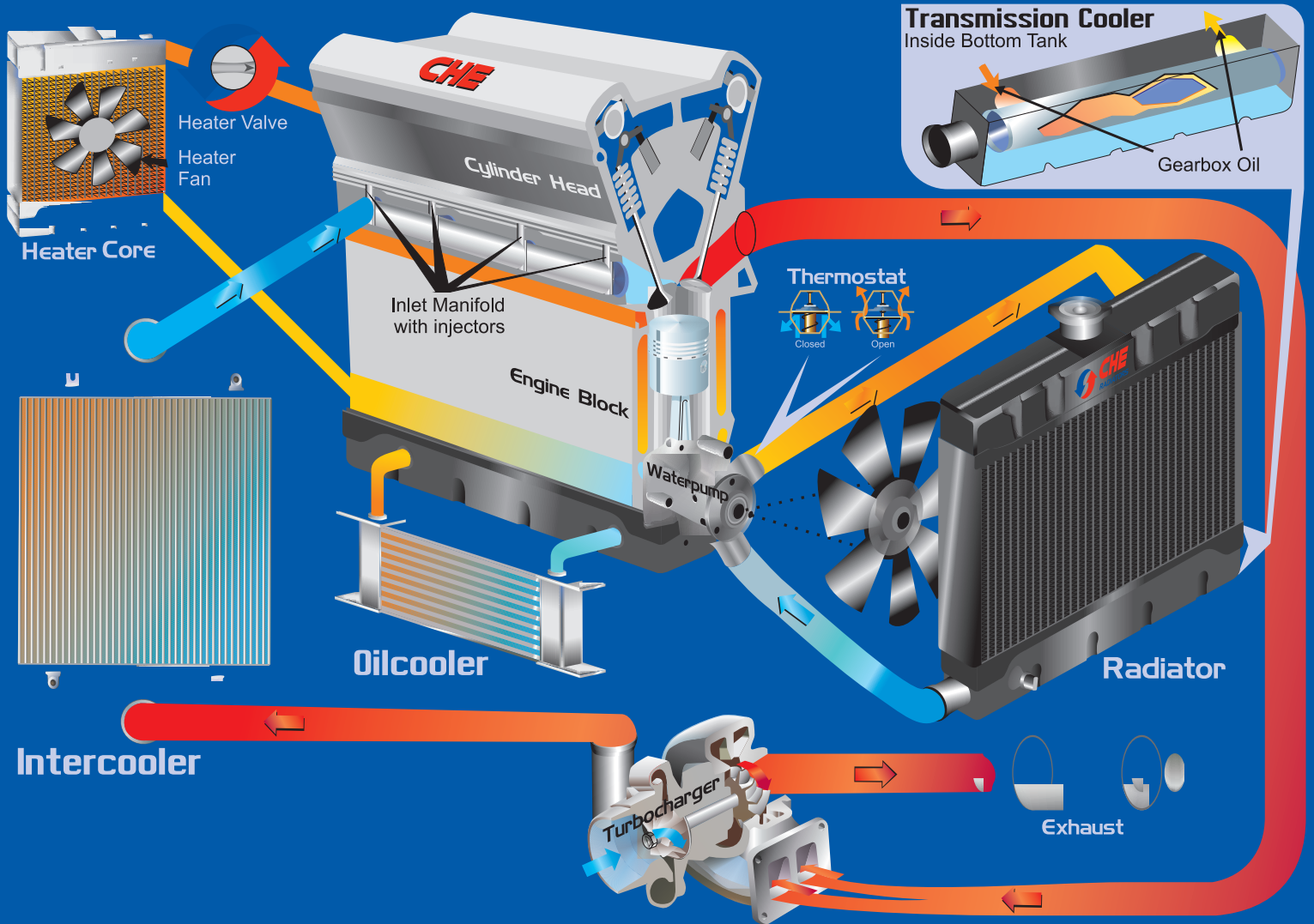

2017 Catalogue

www.CHE.co.za

CONTENTS

1.INTRODUCTION

2.OIL COOLERS

ATLAS COPCO
BELL
CATERPILLAR
FORD
GALLION
HYDROVANE
HYSTER
HYUNDAI
INGERSOL RAND
JOHN DEERE
LAND ROVER
LINDE FORKLIFT
MAGIRUS
MAN
MERCEDES BENZ
NISSAN
SB COOLER
SUZUKI
TOYOTA
ZIP COOLERS

3.RADIATORS

AUSTIN
BELL
FREIGHTLINER
HITACHI
INTERNATIONAL
ISUZU
KOMATSU
MAN
MORGAN
NISSAN
VOLVO
SWIMMING POOL

4.INTERCOOLERS

BELL
FORD
ISUZU
LAND ROVER
MINI
TOYOTA



INTRODUCTION

1. Background

a. Company History

Cape Heat Exchange (Pty) Ltd is situated in Paarl, South Africa, about 50 km outside of Cape Town. The company traces its origins back to the establishment of Cape Radiators in 1968. This year the company celebrated its 20th year of existence, and this clearly positions us as a stabilized company in the heat transfer field.

b. What we do

We are an independently established and dynamic company that develops, manufactures and markets heat exchangers for use in various original equipment manufacturer (OEM) applications, the automotive industry and industrial aftermarkets.

2. Strategy & Vision

a. Vision & objectives

Our vision and objectives are to expand and diversify product lines through continuous and innovative improvement, not only product development but also keeping up to date with the latest machinery.

b. Mission statement

Our product quality is a direct result of the many years' experience and the use of the most modern techniques and advances in heat transfer technology (HTT). Our product diversity and experience gains us the recognition of South Africa's most complete supplier of high quality radiator products and industrial coolers. We not only manufacture new products but are also able to repair, clean and test heat exchangers. We also have a fully functional radiator shop on site and is able to help customers while they wait.



INTRODUCTION

c. Values

Customer service through superlative service. In that we strive to work with a client to meet their requirements no matter the specifications.

d. Growth strategy

To adapt to ever changing nature of the industry and the versatility of the field that we supply.

3. Products & Services

a. Products

Our products include the following:

- * Inter coolers
- * Tube & shell oil coolers
- * All types of marine coolers
- * Hydraulic oil coolers
- * Automotive oil coolers
- * Steam heat exchangers
- * Oil coolers in various designs
- * Heavy duty radiator cores
- * Special application radiator cores
- * Aftercoolers
- * Plastic & brass radiator tanks
- * Spiral tubes
- * Withnell tube oil coolers
- * Transmission oil coolers

b. Services

Manufacturing of new heat transfer products, but also the clean, test and repair of older products. Furthermore the radiator shop are able to handle and help walk in customers that have an emergency or whether they are in need for some expert advice.

c. Business competitiveness

We have a number of warehouses throughout South Africa and this enables us to reach a broader client base and also supply clients more effectively no matter their location. Our company is the only manufacturer of NCN aluminium heat exchanger in Africa. We are able to manufacture aluminium heat exchangers to client specifications

OILCOOLERS

OILCOOLER-ATLAS COPCO

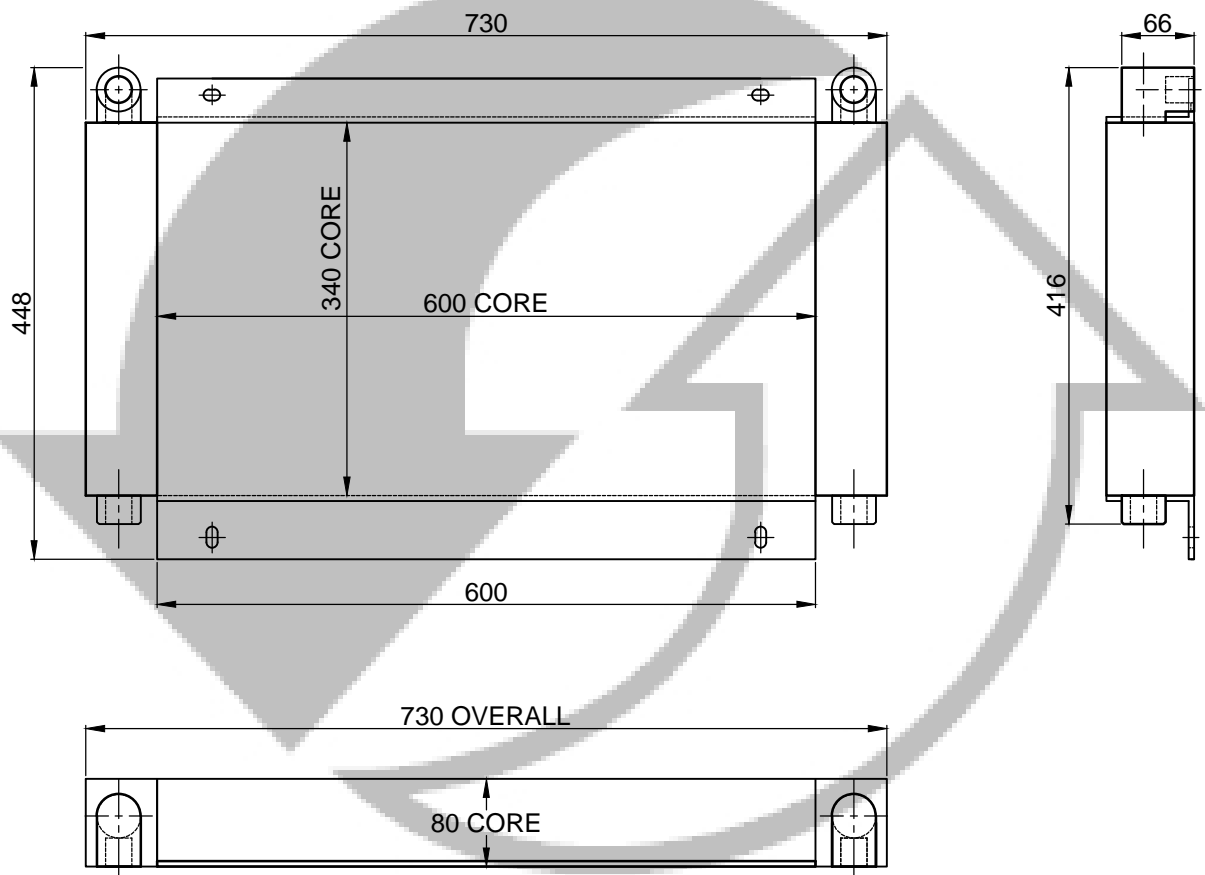

MODEL:ATLAS COPCO XA 85

PART NUMBER:OIL614ATL1COM

OILCOOLER-ATLAS COPCO

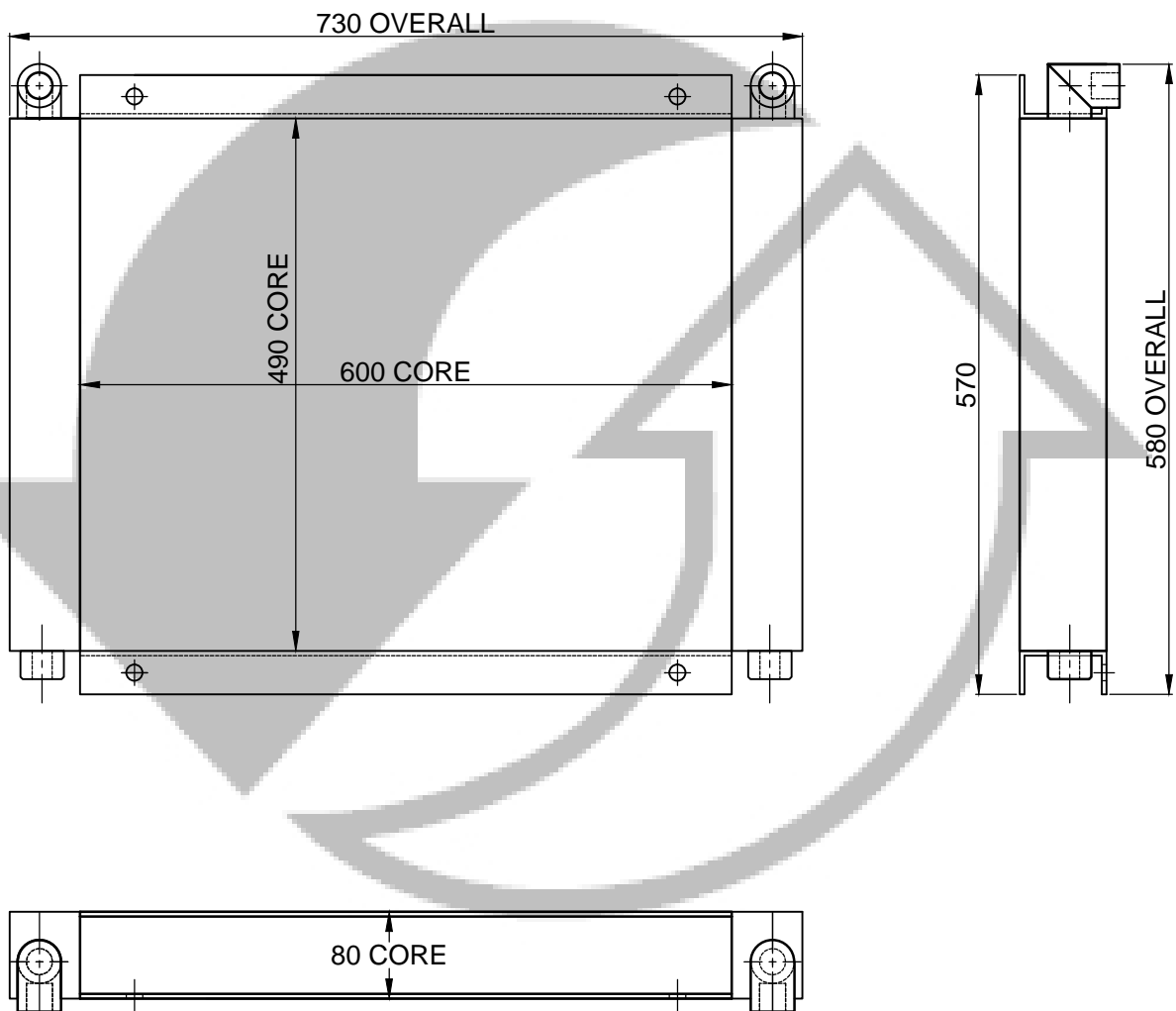

MODEL:ATLAS COPCO

PART NUMBER:OIL614ATL3COM

OILCOOLER-ATLAS COPCO

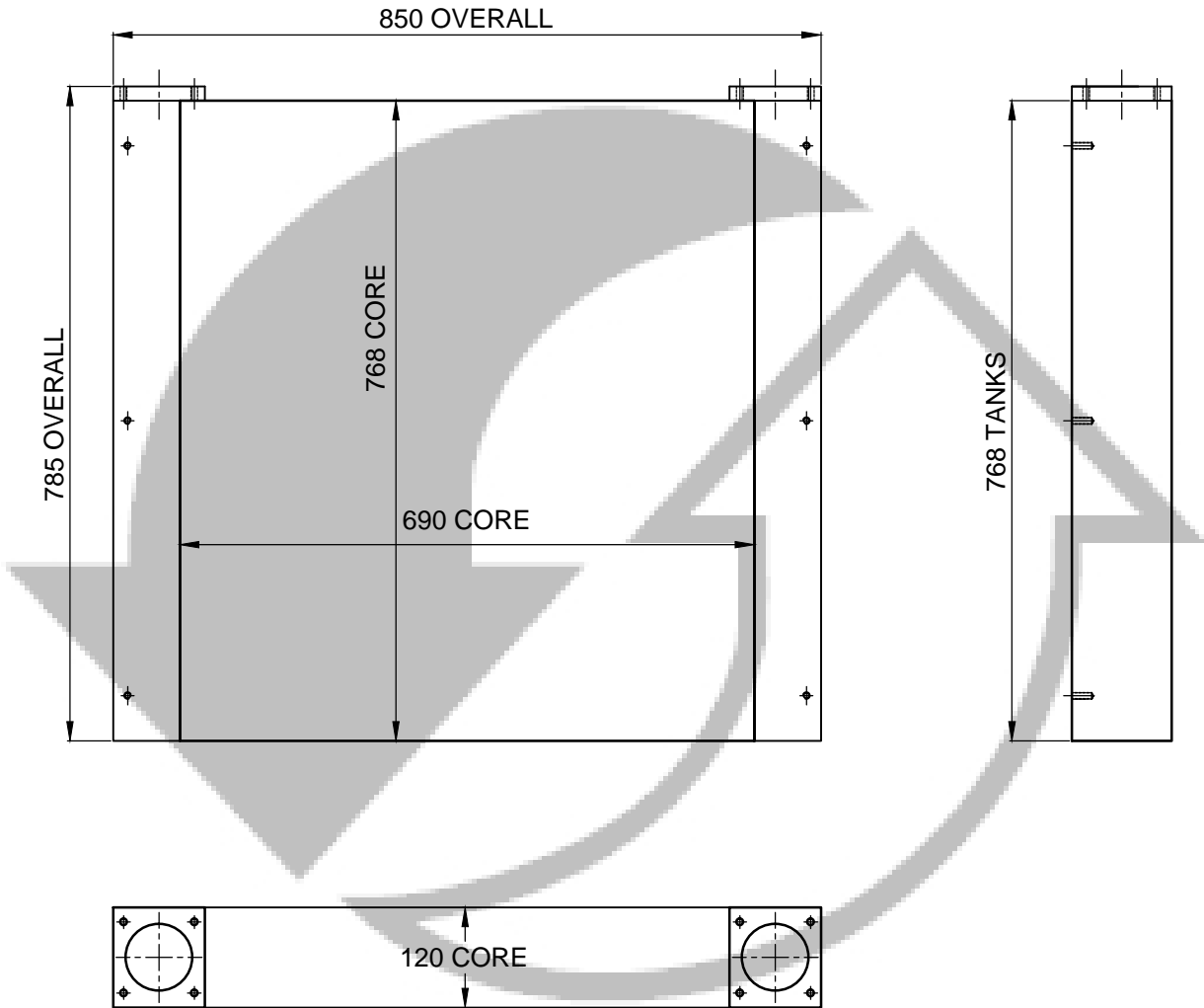

MODEL:ATLAS COPCO

PART NUMBER:OIL684ATL1COM

OILCOOLER-BELL

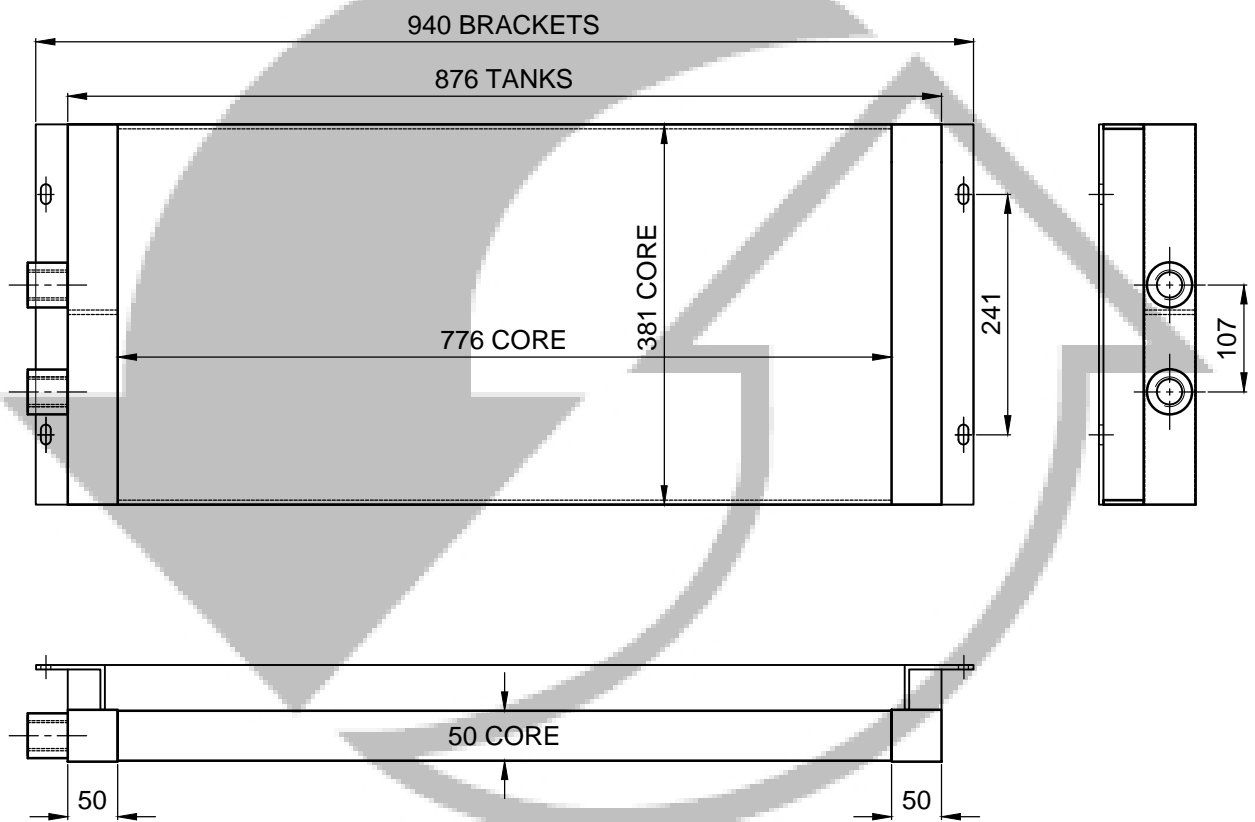

MODEL: BELL B25_API

PART NUMBER: OIL760BEL1COM

OILCOOLER-BELL

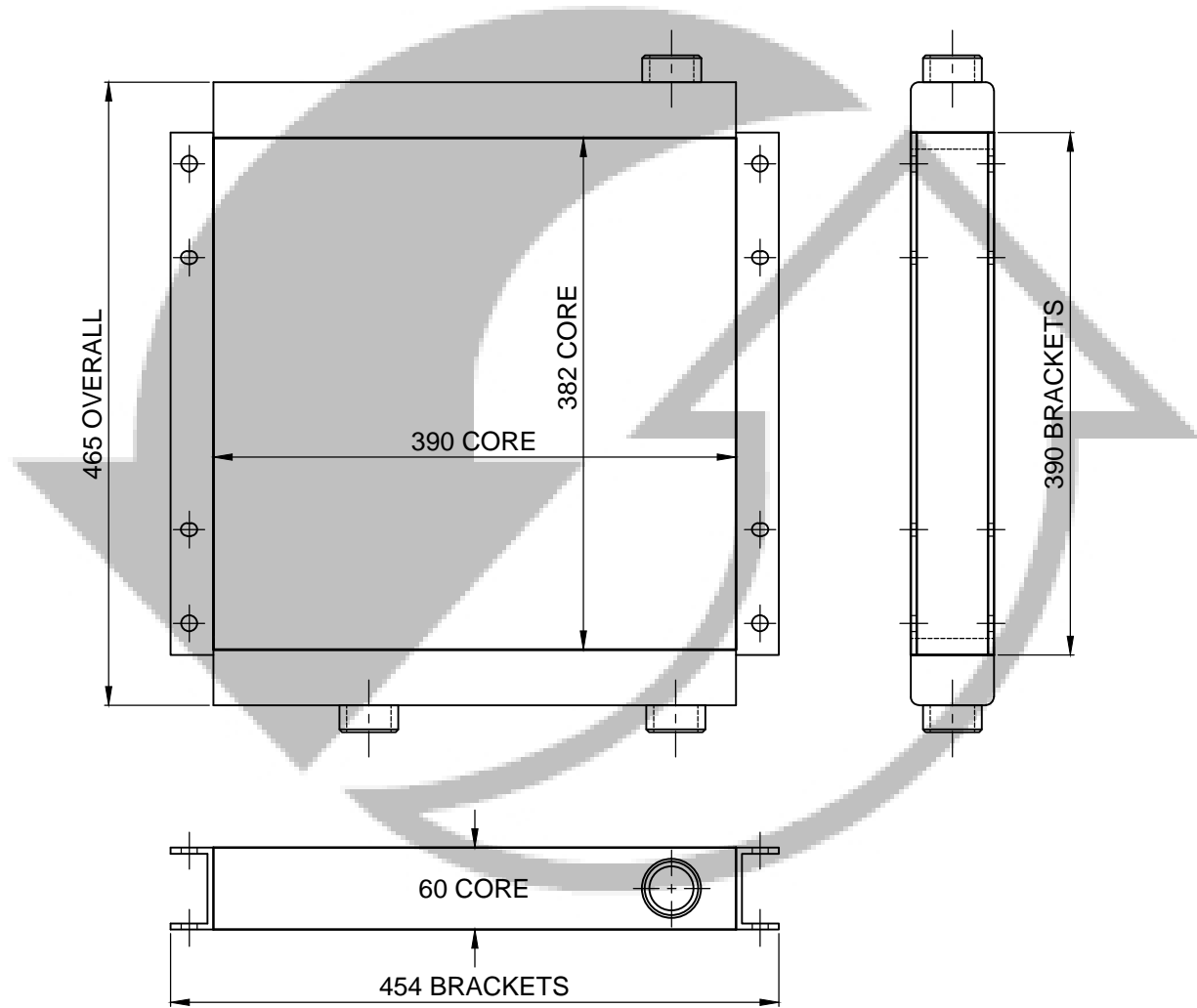

MODEL: BELL-B40

PART NUMBER: OIL390BEL1COM

OILCOOLER-BELL

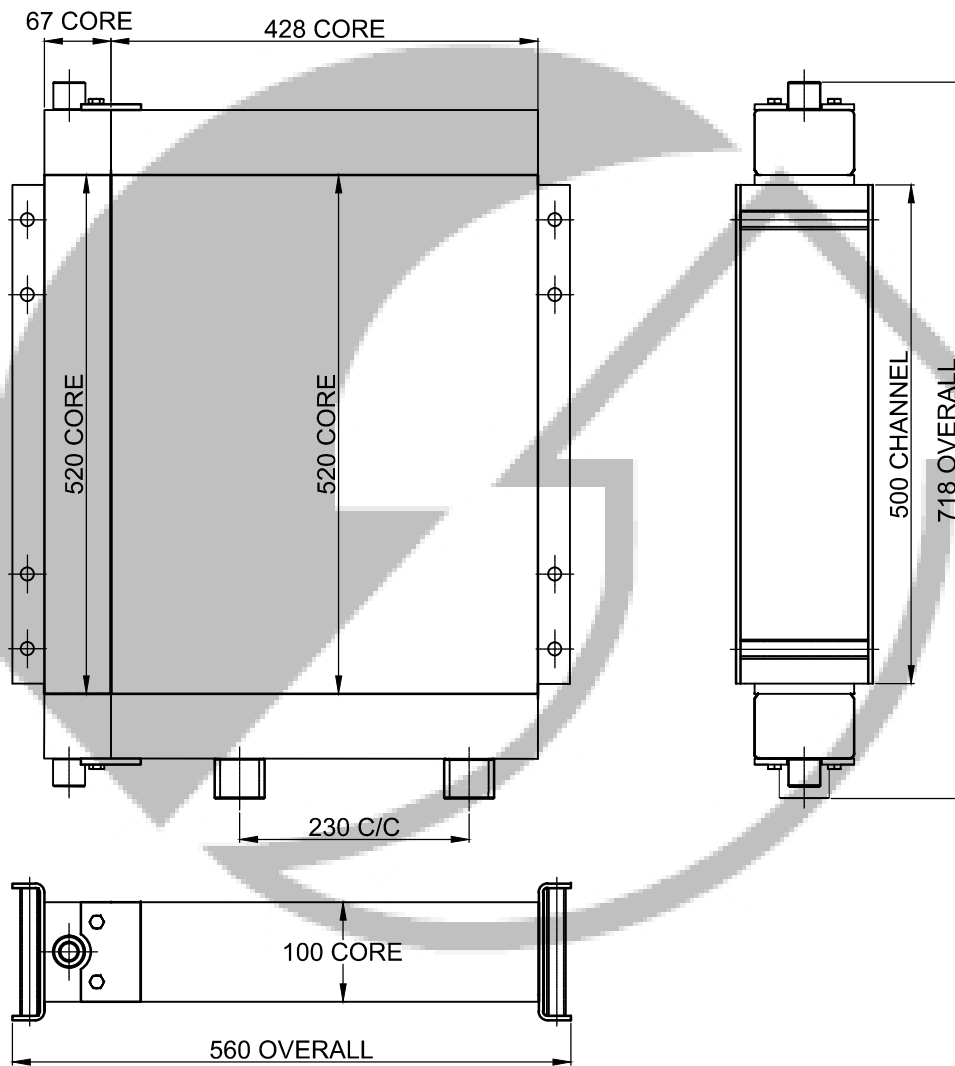

MODEL: BELL

PART NUMBER: OIL533BEL1COM

OILCOOLER-BELL

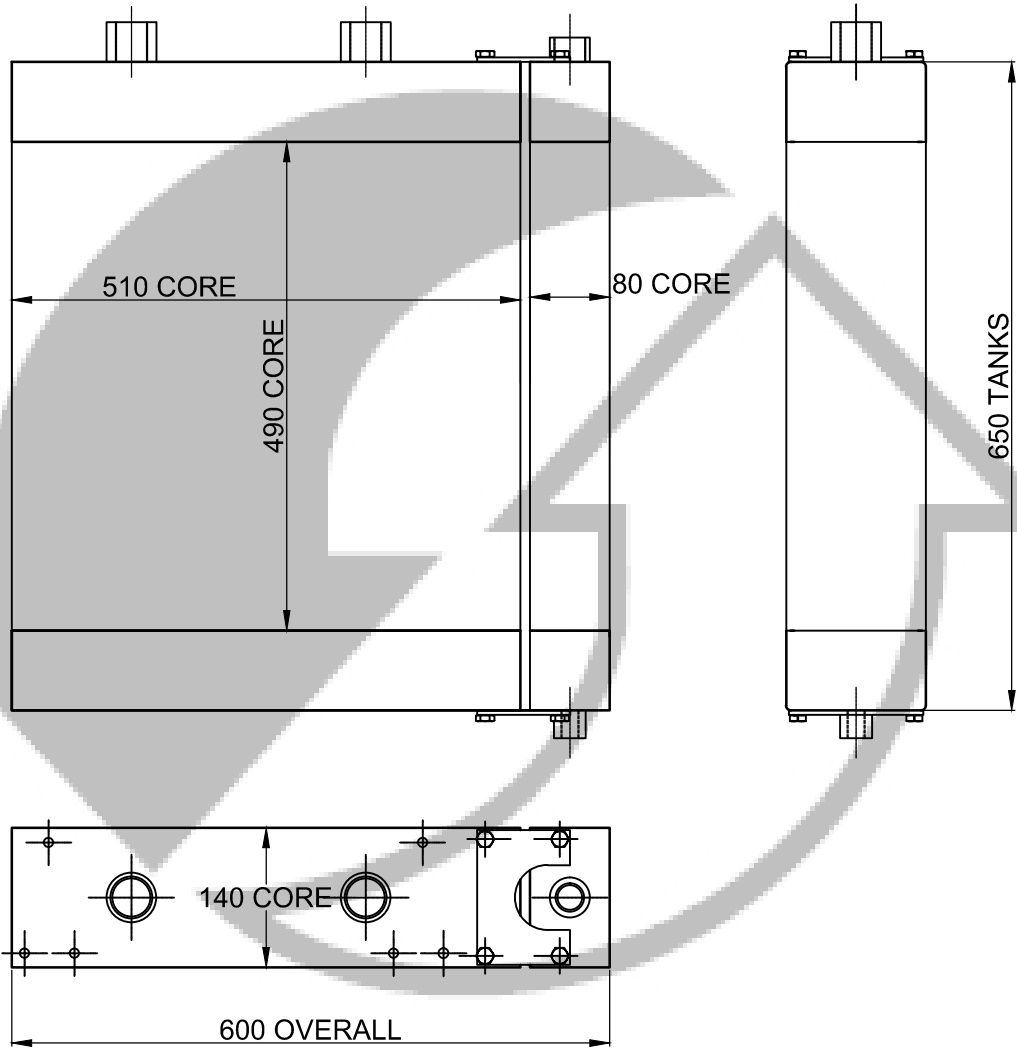

MODEL: BELL

PART NUMBER: OIL490BEL1COM

OILCOOLER-CATERPILLAR

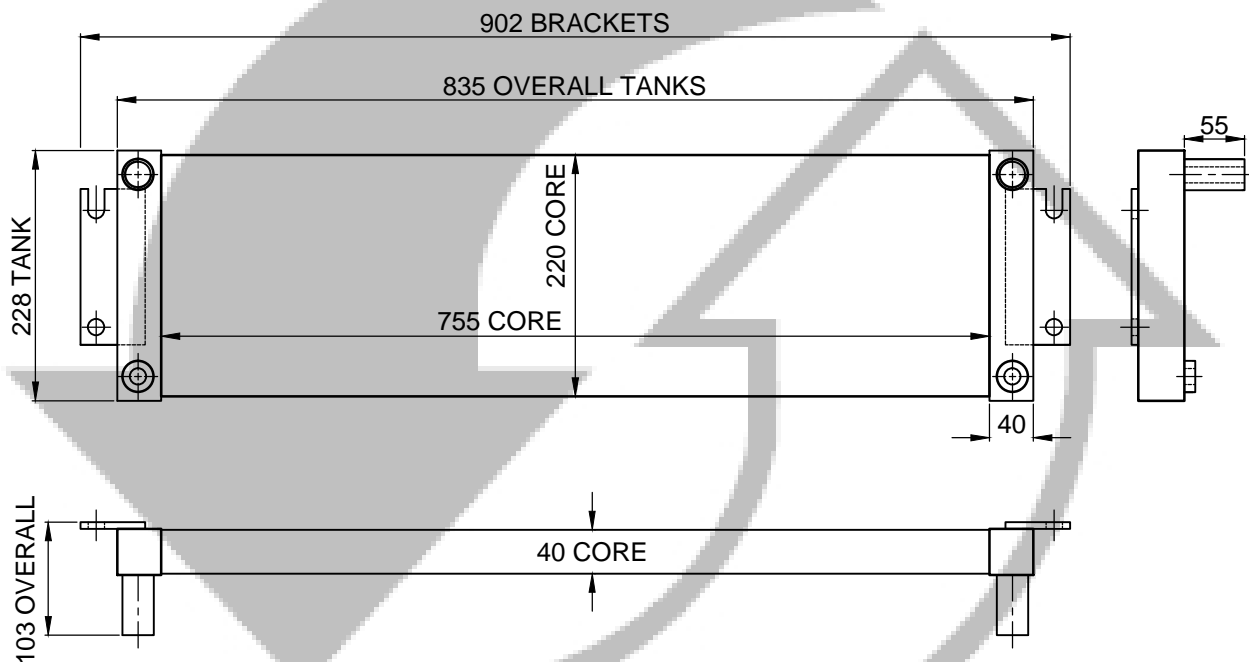

ORIGINAL UNIT IS A STEEL UNIT.



MODEL:CATERPILLAR 140G

PART NUMBER:OIL739CAT1COM

OILCOOLER-FORD



MODEL:FORD

PART NUMBER:TMOC333FOR1

OILCOOLER-GALLION

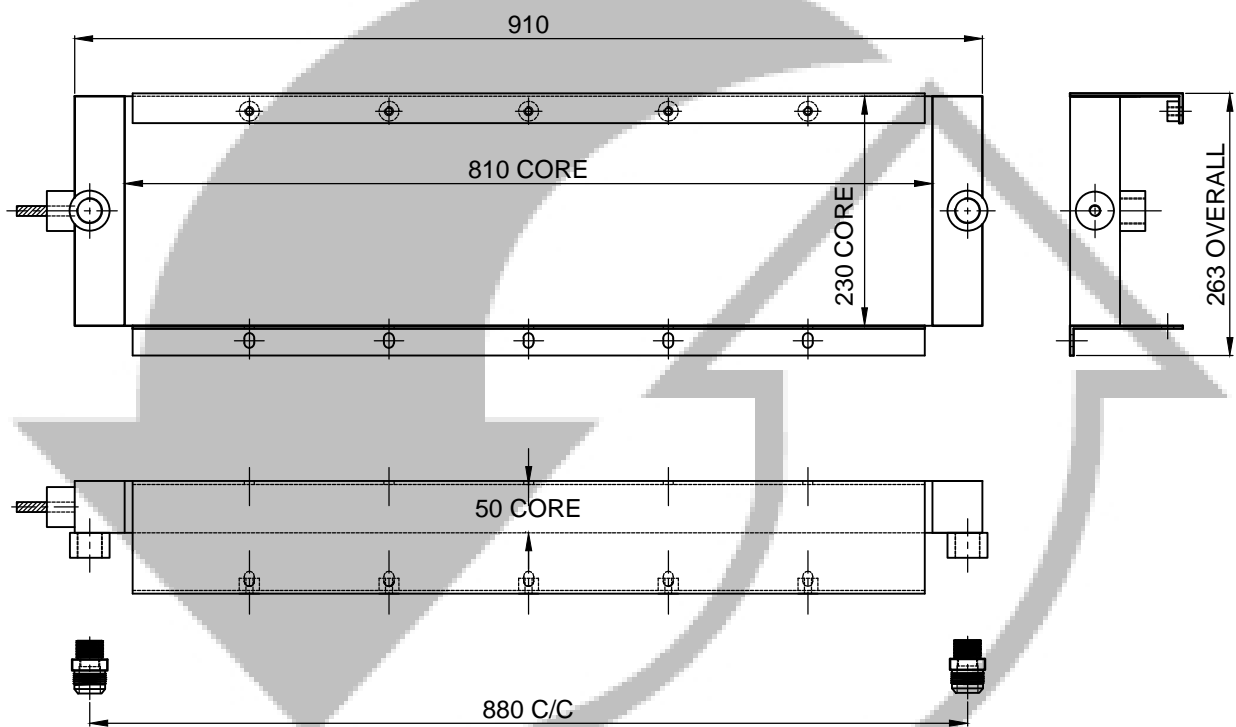

ORIGINAL UNIT IS A STEEL UNIT.



MODEL:GALLION T500/T600

PART NUMBER:OIL794GAL1COM

OILCOOLER-HYDROVANE

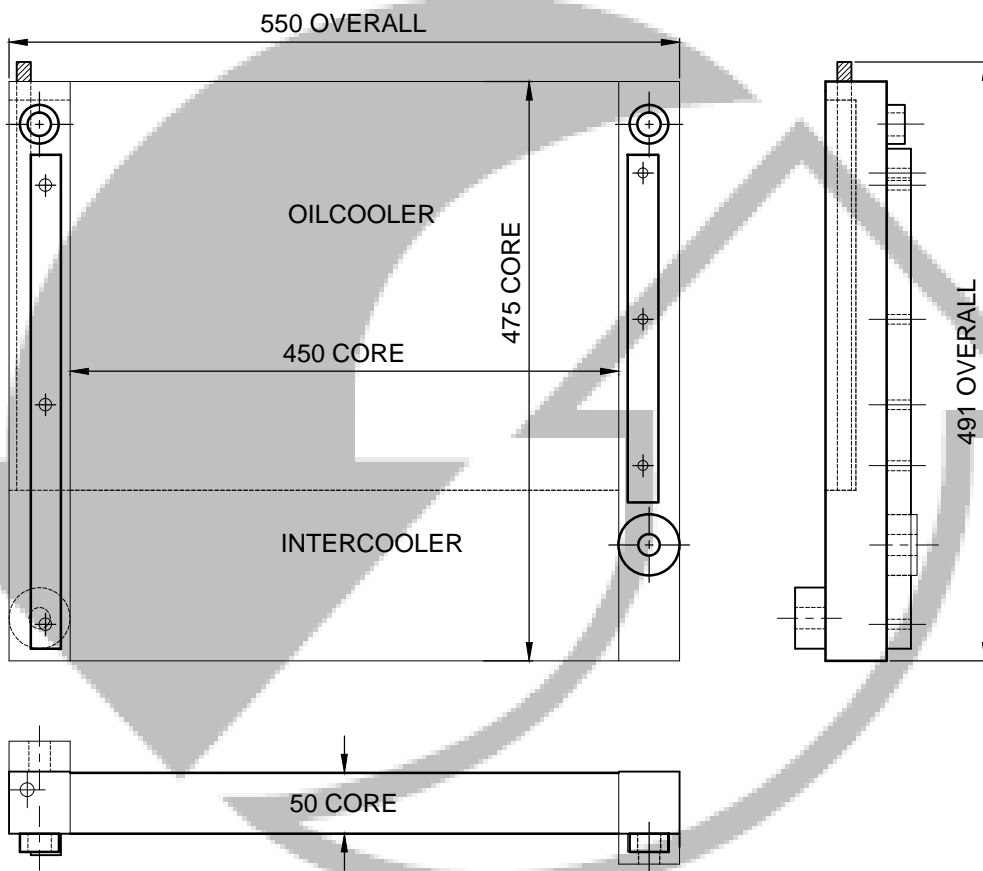

MODEL:HYDROVANE

PART NUMBER:OIL434HYD1COM

OILCOOLER-HYDROVANE

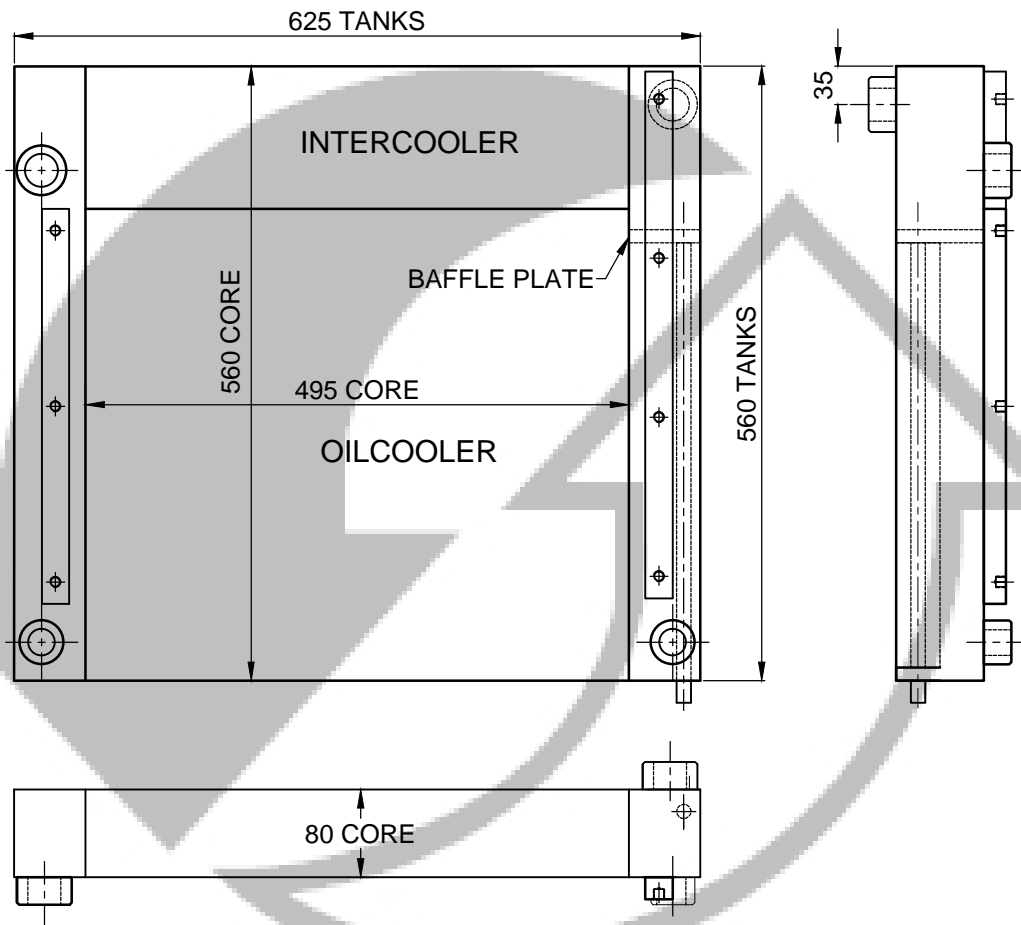

MODEL:HYDROVANE

PART NUMBER:OIL509HYD1COM

OILCOOLER-HYDROVANE

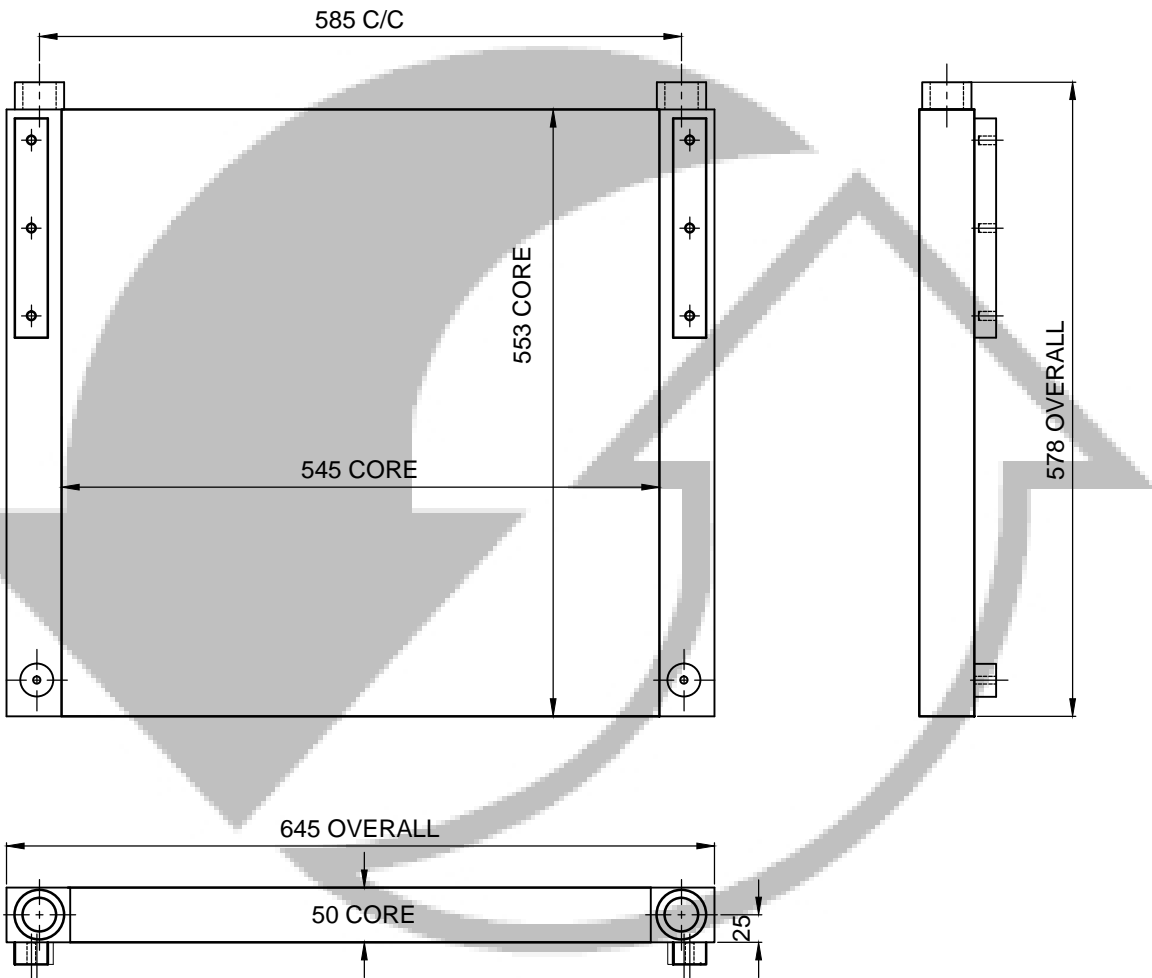

MODEL:HYDROVANE

PART NUMBER:OIL529HYD1COM

OILCOOLER-HYDROVANE

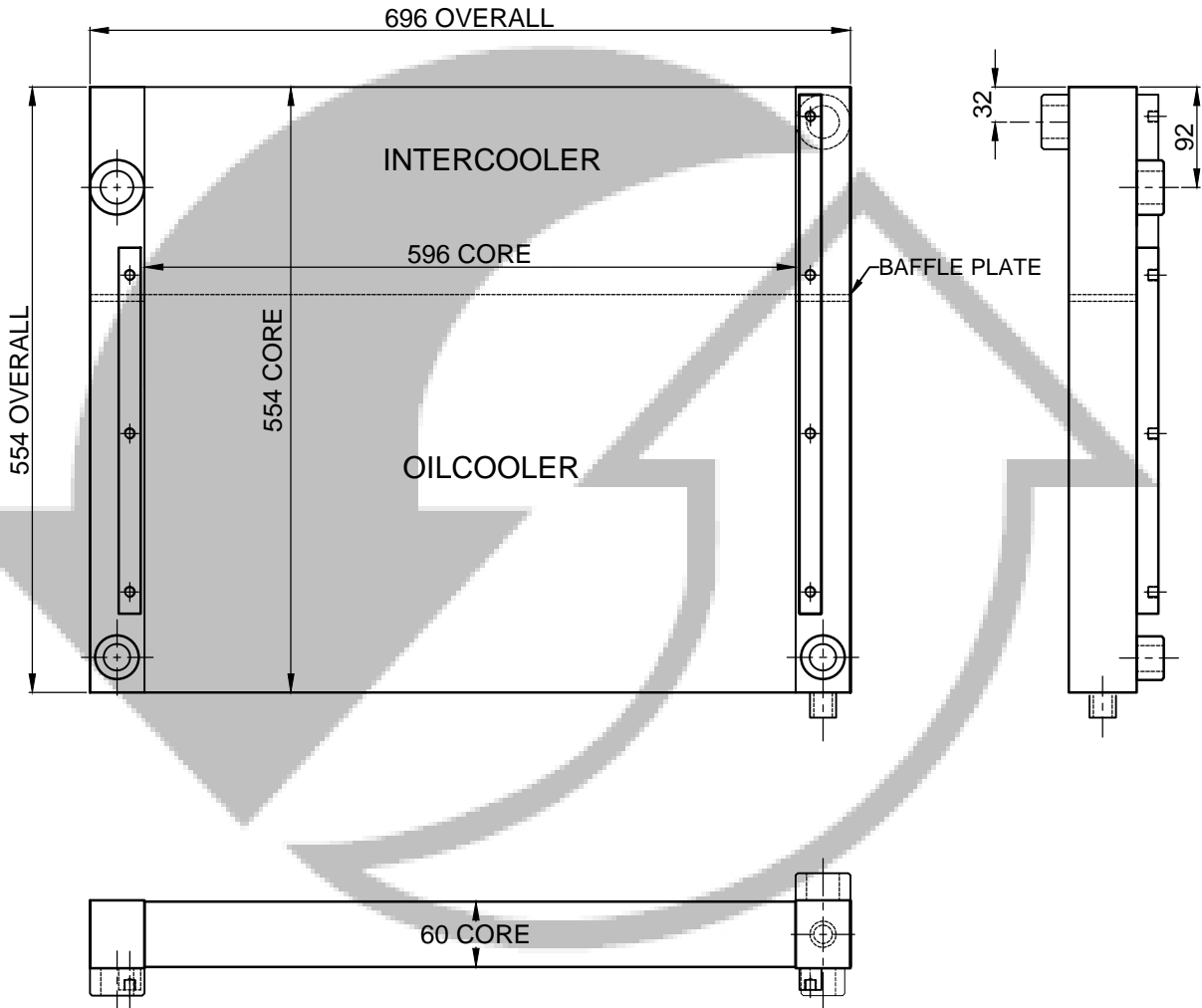

MODEL:HYDROVANE

PART NUMBER:OIL580HYD1COM

OILCOOLER-HYDROVANE

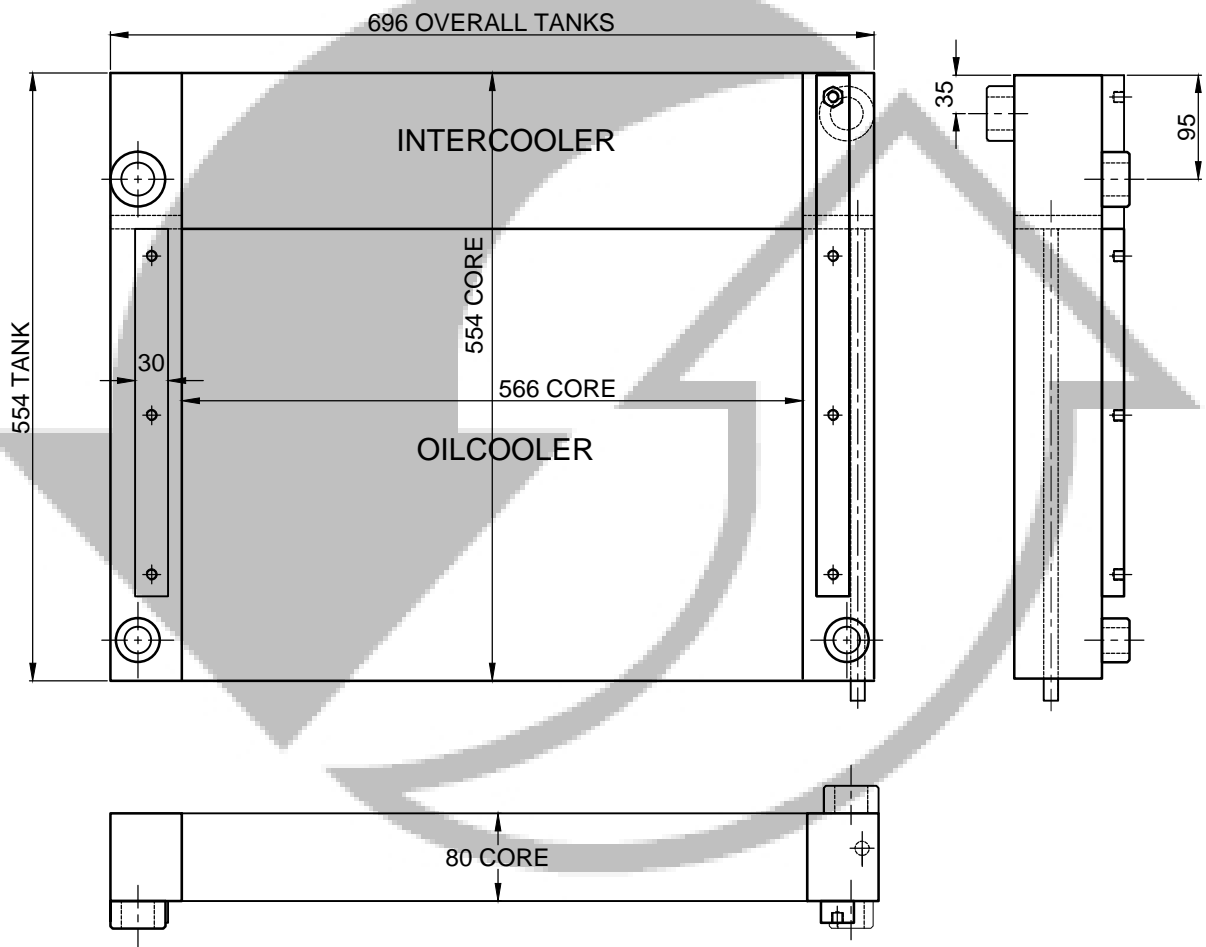

MODEL:HYDROVANE

PART NUMBER:OIL580HYD3COM

OILCOOLER-HYDROVANE

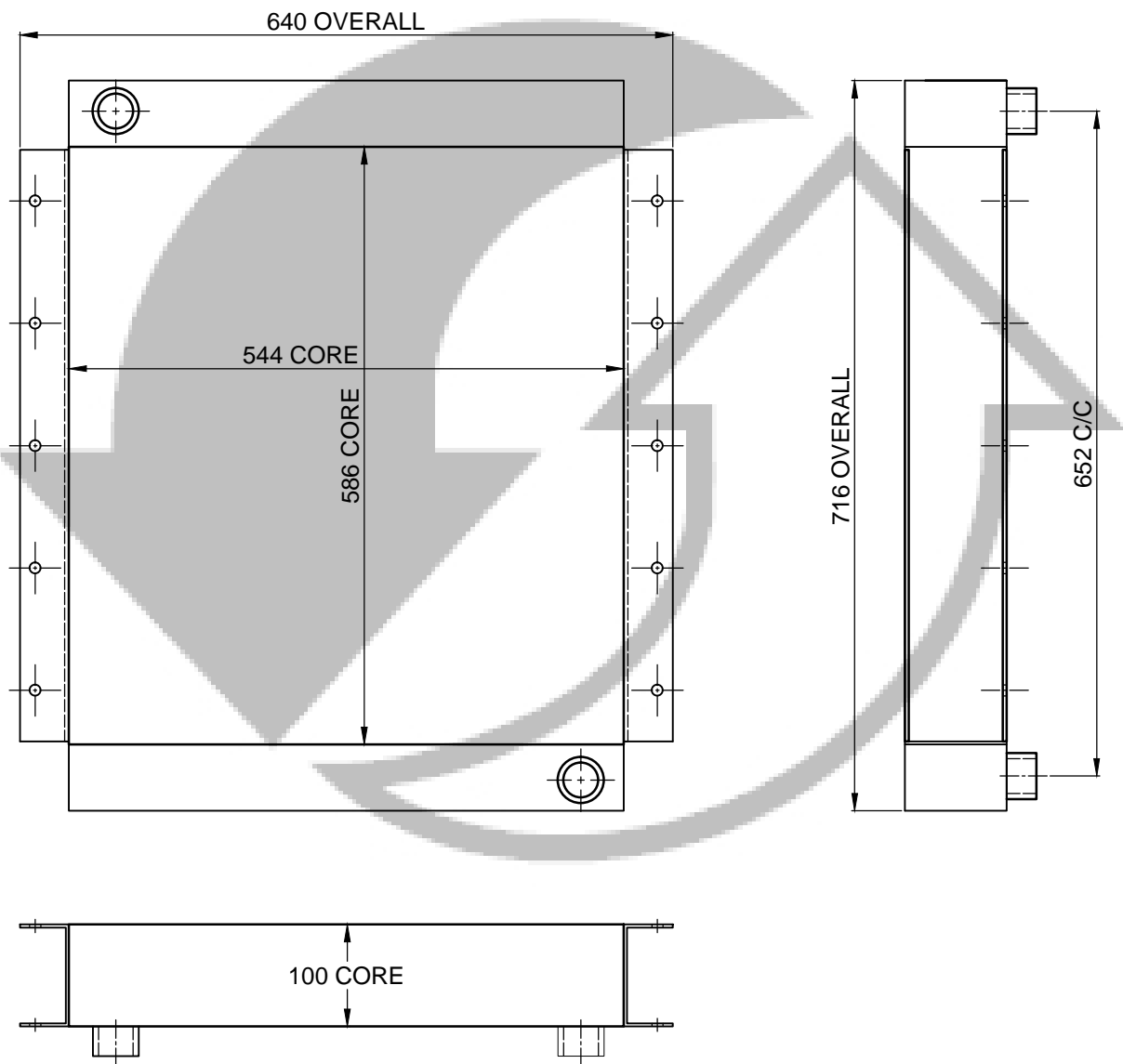

MODEL:HYDROVANE

PART NUMBER:OIL600HYD1COM

OILCOOLER-HYDROVANE

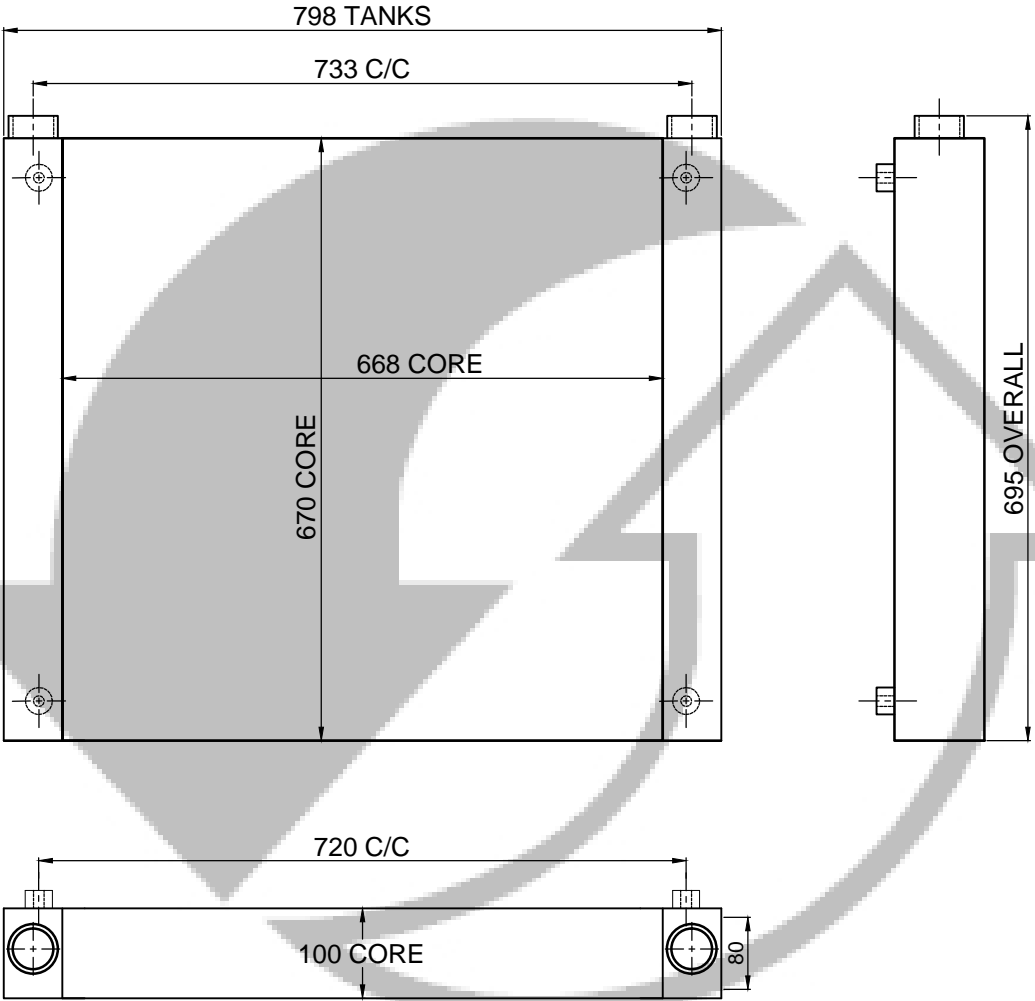

MODEL:HYDROVANE

PART NUMBER:OIL602 HYD1COM

OILCOOLER-HYDROVANE

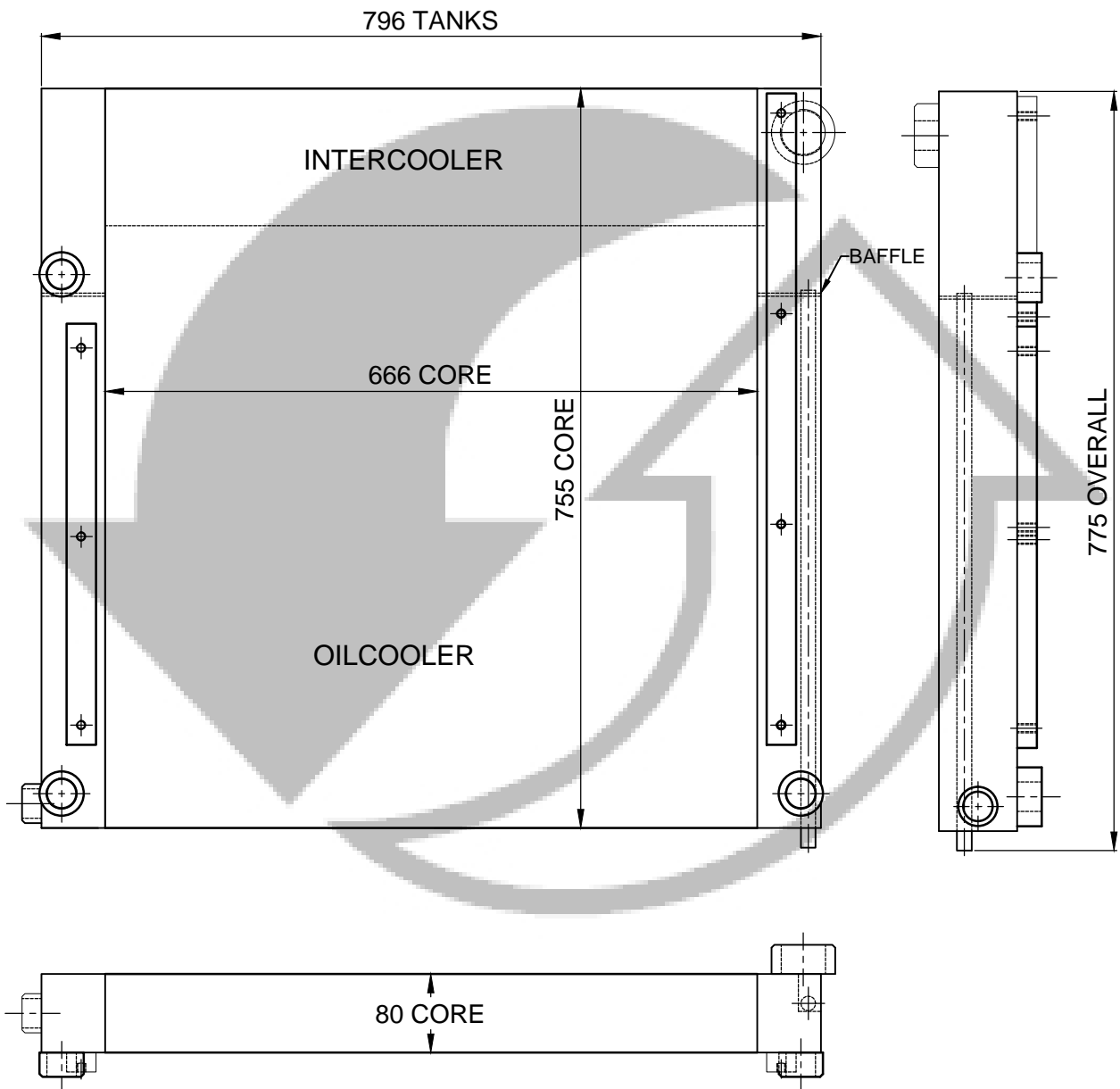

MODEL:HYDROVANE

PART NUMBER:OIL680HYD1COM

OILCOOLER-HYSTER

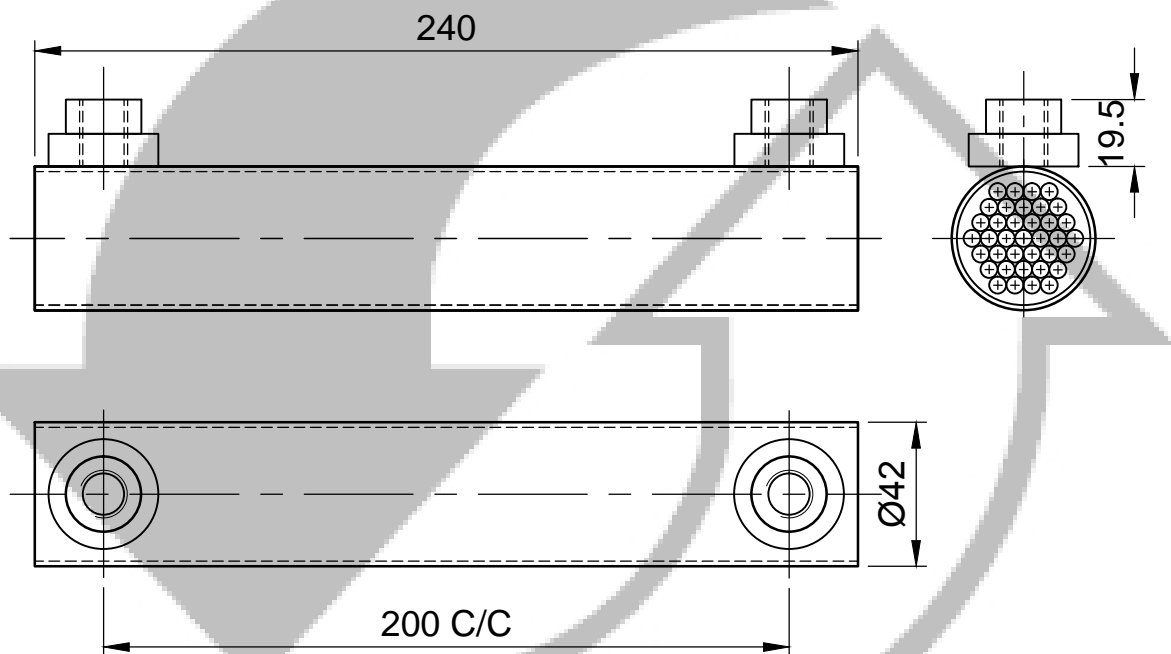

MODEL:HYSTER

PART NUMBER:TMOC240HYS1COM

OILCOOLER-HYSTER

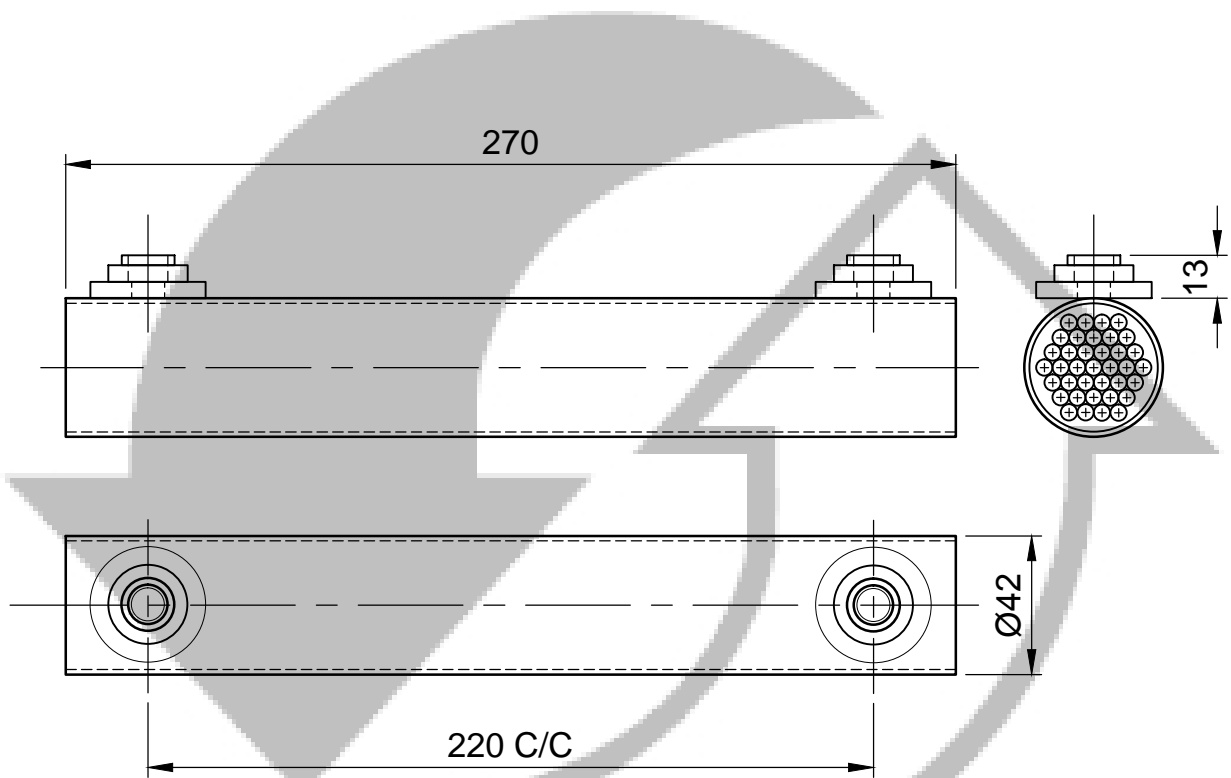

MODEL:HYSTER

PART NUMBER:TMOC270HYS1COM

OILCOOLER-HYSTER

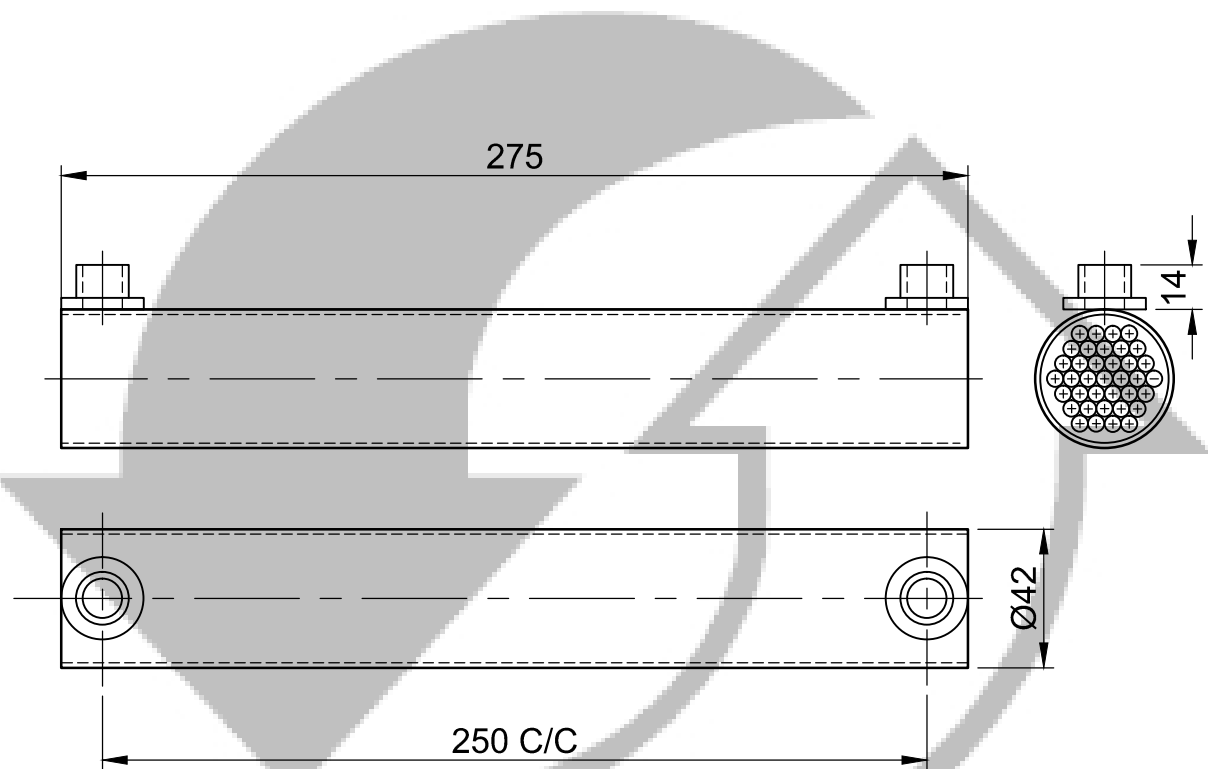

MODEL:HYSTER

PART NUMBER:TMOC275HYS1COM

OILCOOLER-HYSTER

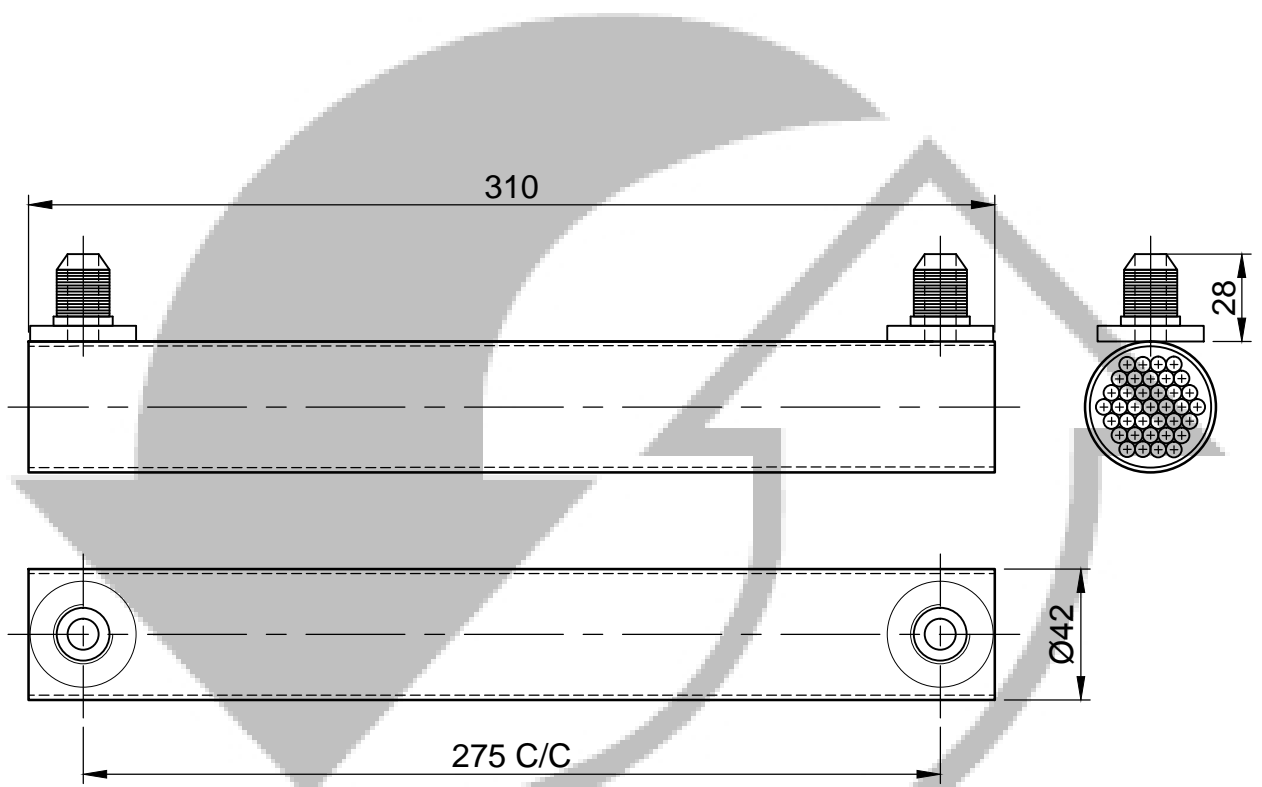

MODEL:HYSTER

PART NUMBER:TMOC310HYS1COM

OILCOOLER-HYSTER

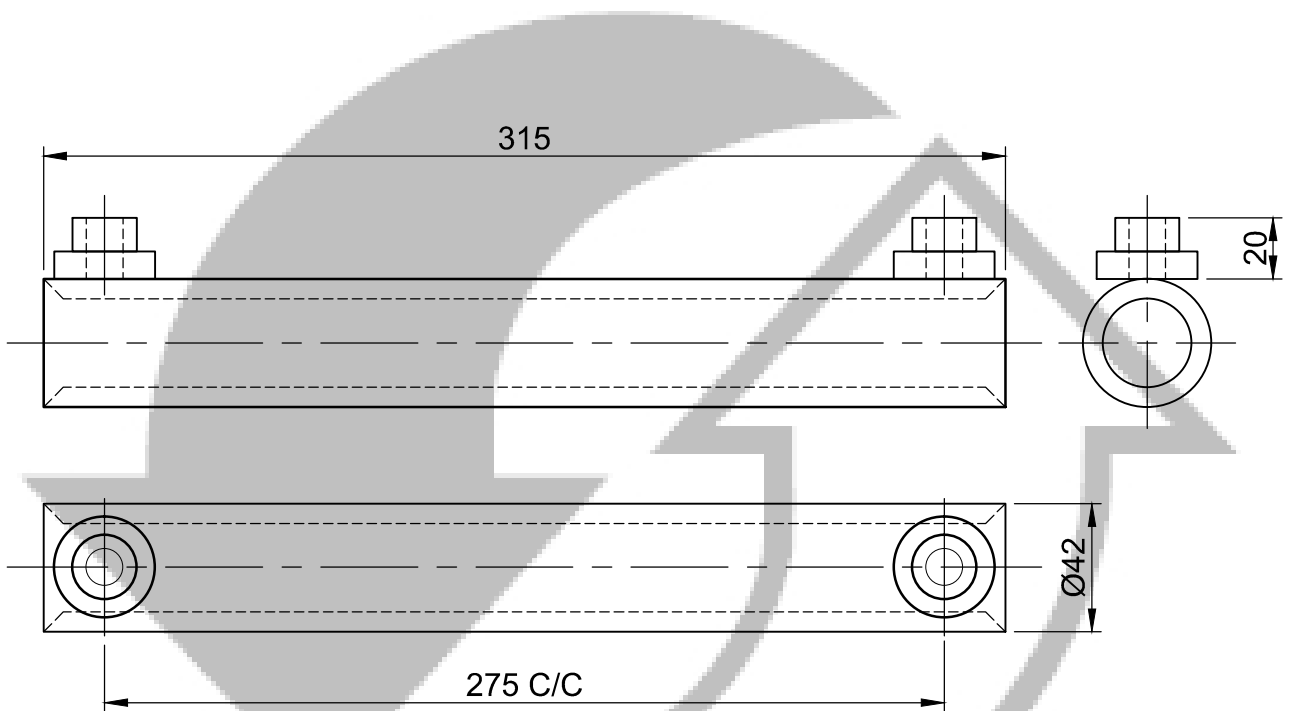

MODEL:HYSTER

PART NUMBER:TMOC-DB315HYS1COM

OILCOOLER-HYSTER

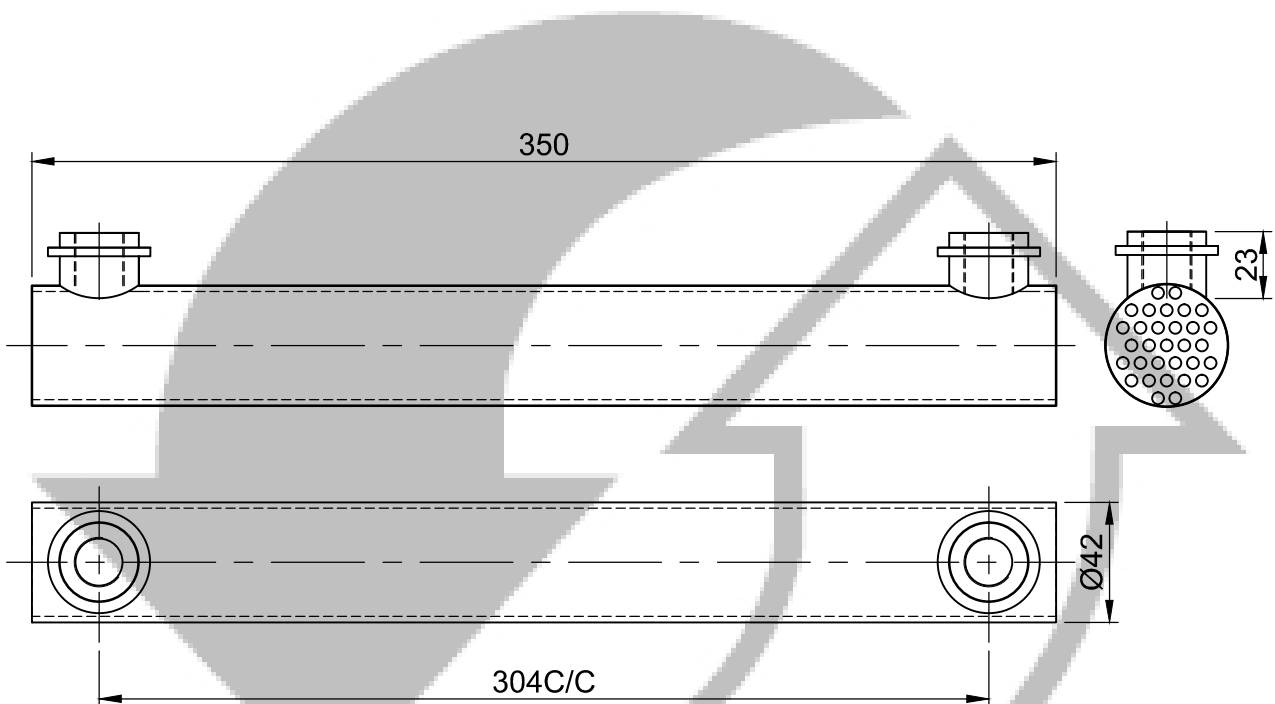

MODEL:HYSTER

PART NUMBER:TMOC350HYS1COM

OILCOOLER-HYSTER

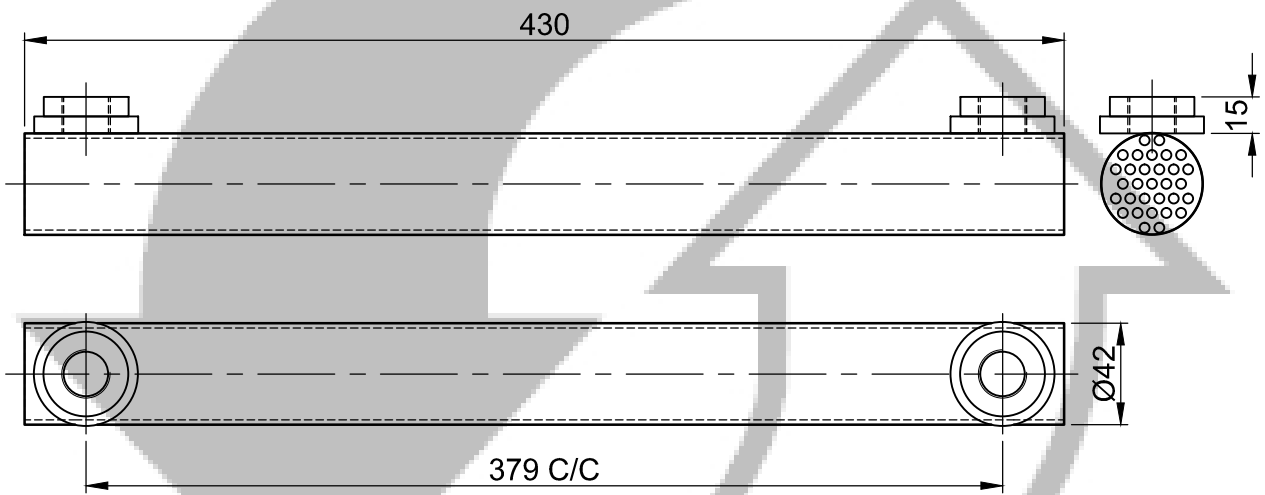

MODEL:HYSTER

PART NUMBER:TMOC430HYS1COM

OILCOOLER-HYUNDAI

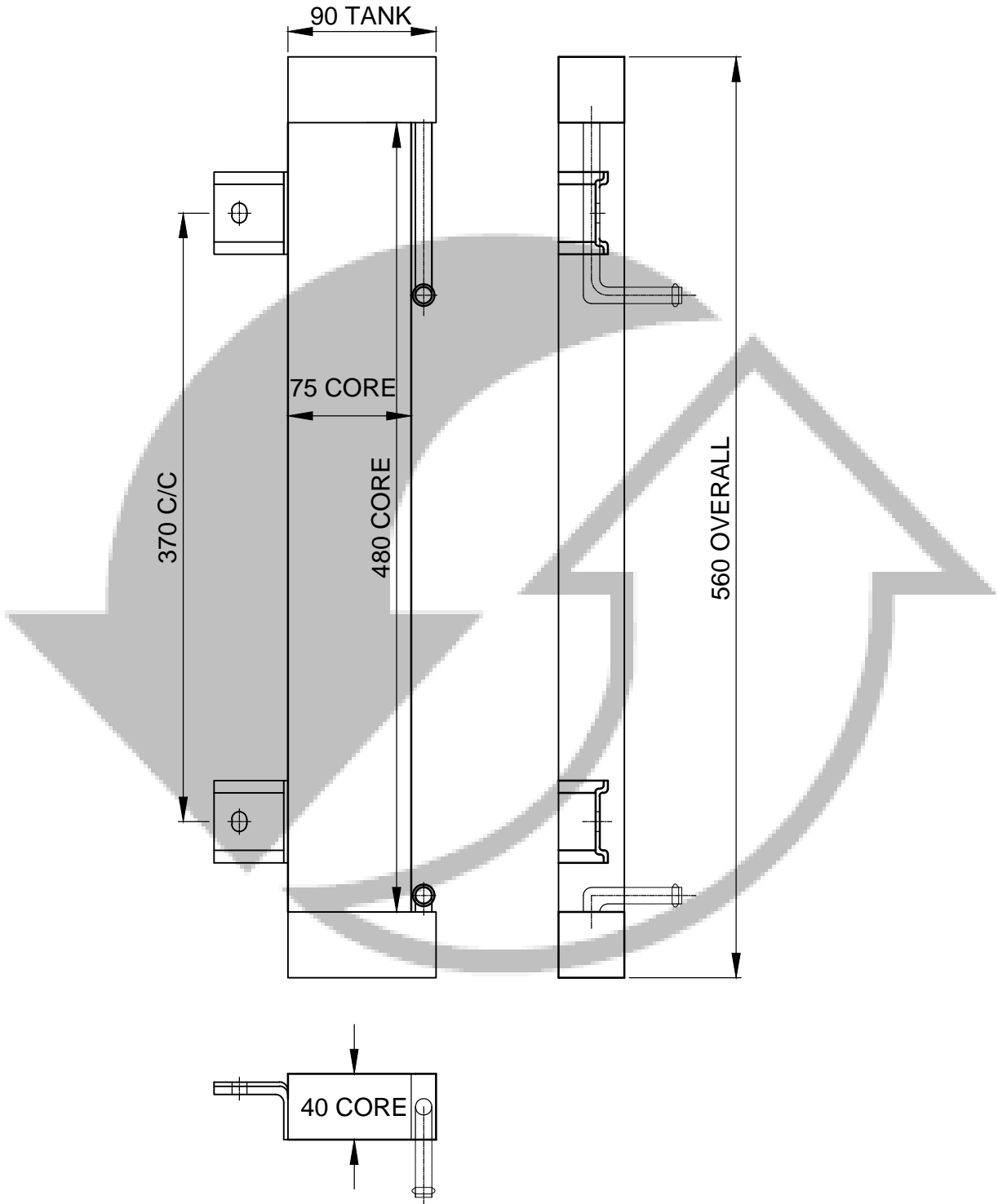

MODEL:HYUNDAI

PART NUMBER:OIL484HYU1COM

OILCOOLER-INGERSOL RAND

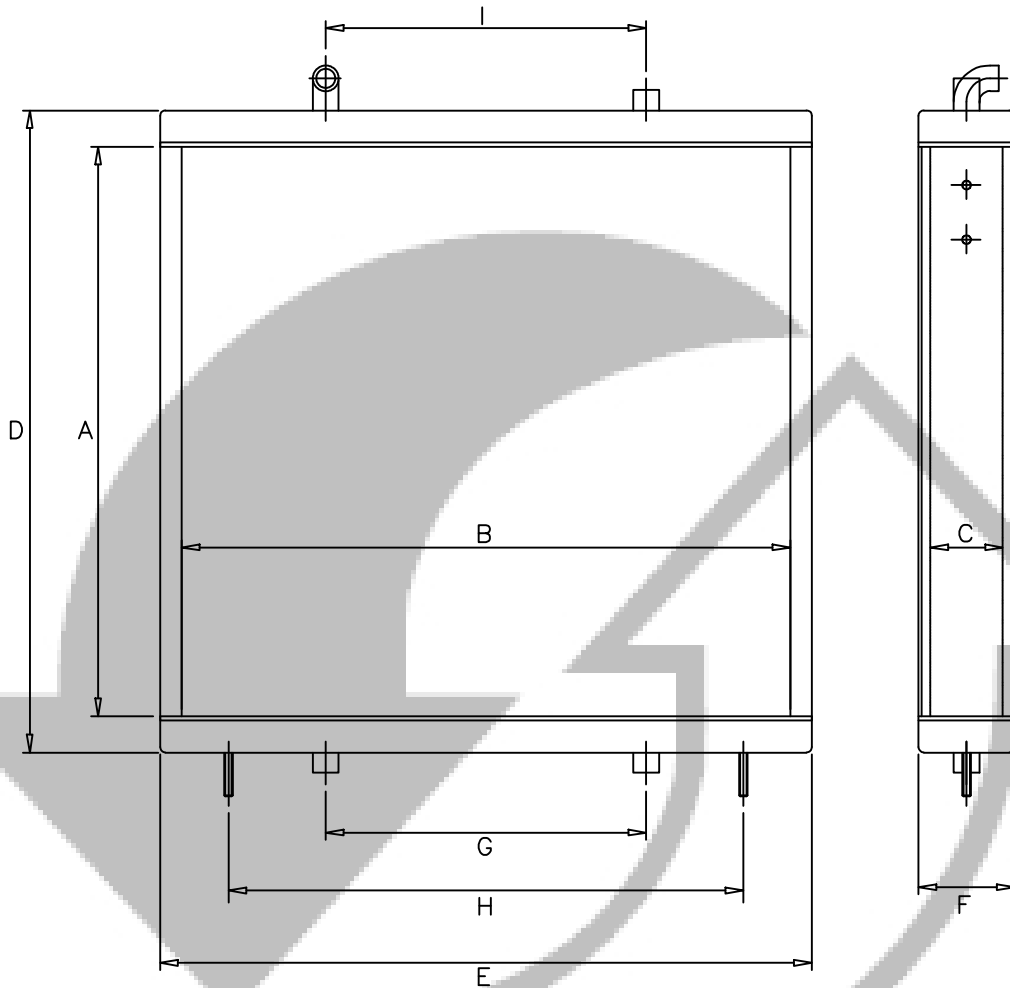

MODEL	CORE			OVERALL			OTHER			PART
	A	B	C	D	E	F	G	H	I	
533ING1	501	587	60	601	610	60	300	482	374	533ING1
584ING1	556	682	60	656	727	60	276	628	508	584ING1
686ING1	658	758	60	758	799	60	251	705	508	686ING1
838ING1	870	910	60	970	971	60	317	673	-	838ING1



MODEL:INGERSOL RAND DR 125,210,250,365
 PART NUMBER:OIL533ING1COM,OIL5841COM,
 OIL686ING1COM,OIL8381COM

OILCOOLER-INGERSOL RAND

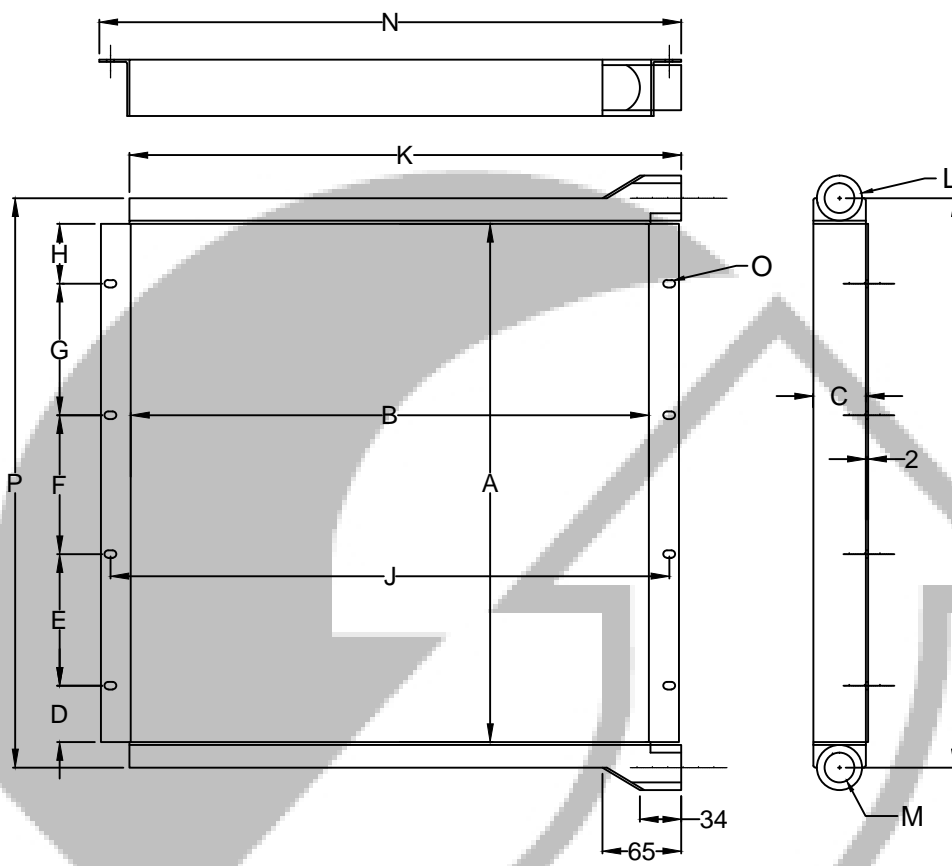

A	B	C	D	E	F	G	H	I	J	K	L	M	N	O	P
895	910	60	76.5	254	254	254	76.5	995	865	860	Ø57	1½"NPT	890	12x8 slot	995
735	728	60	38	228	228	228	38	845	768	765	Ø60	1½"NPT	798	12x8 slot	835



MODEL:INGERSOL RAND

PART NUMBER:915 ING1,760ING1

OILCOOLER-JOHN DEERE

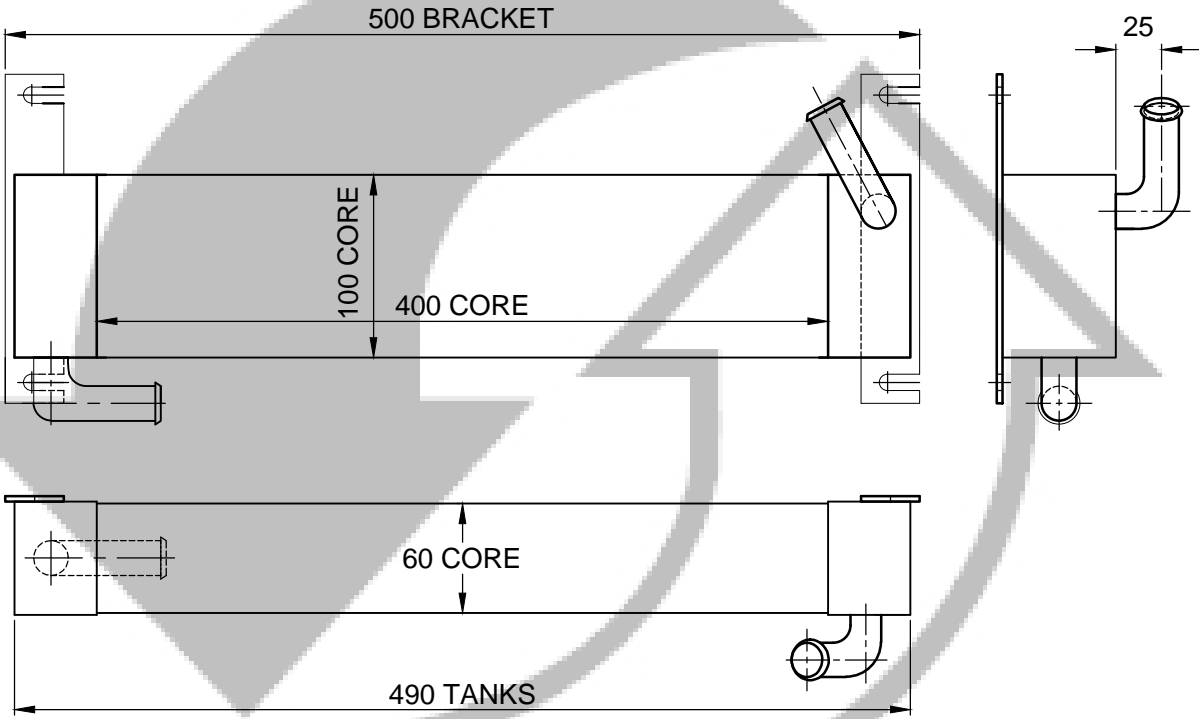

MODEL:JOHN DEERE

PART NUMBER:OIL400JOH1COM

OILCOOLER-JOHN DEERE

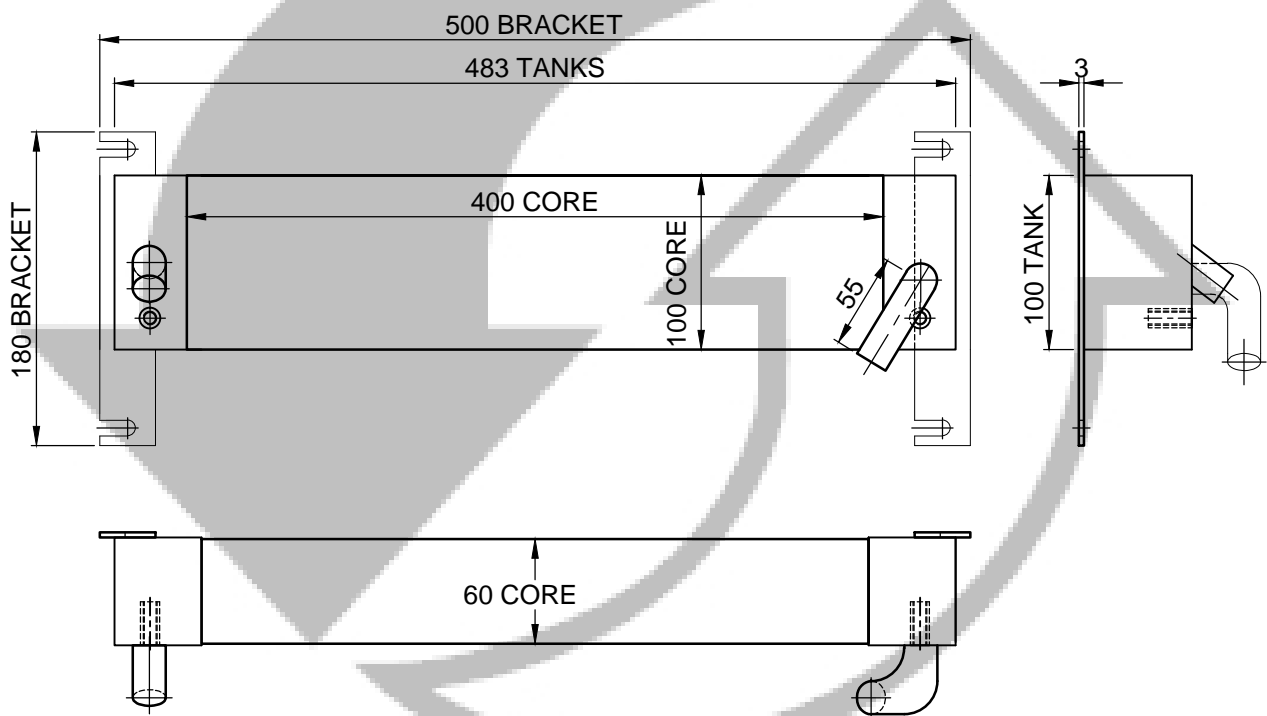

MODEL:JOHN DEERE

PART NUMBER:OIL400JOH2COM

OILCOOLER-JOHN DEERE

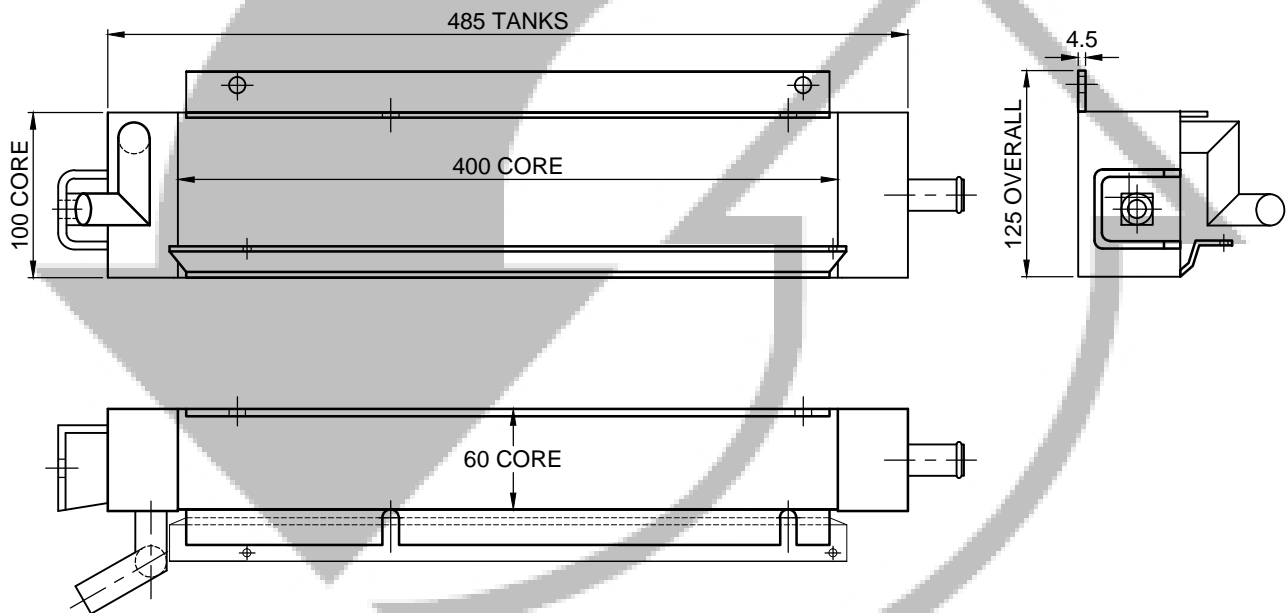

MODEL:JOHN DEERE

PART NUMBER:OIL400JOH3COM

OILCOOLER-JOHN DEERE

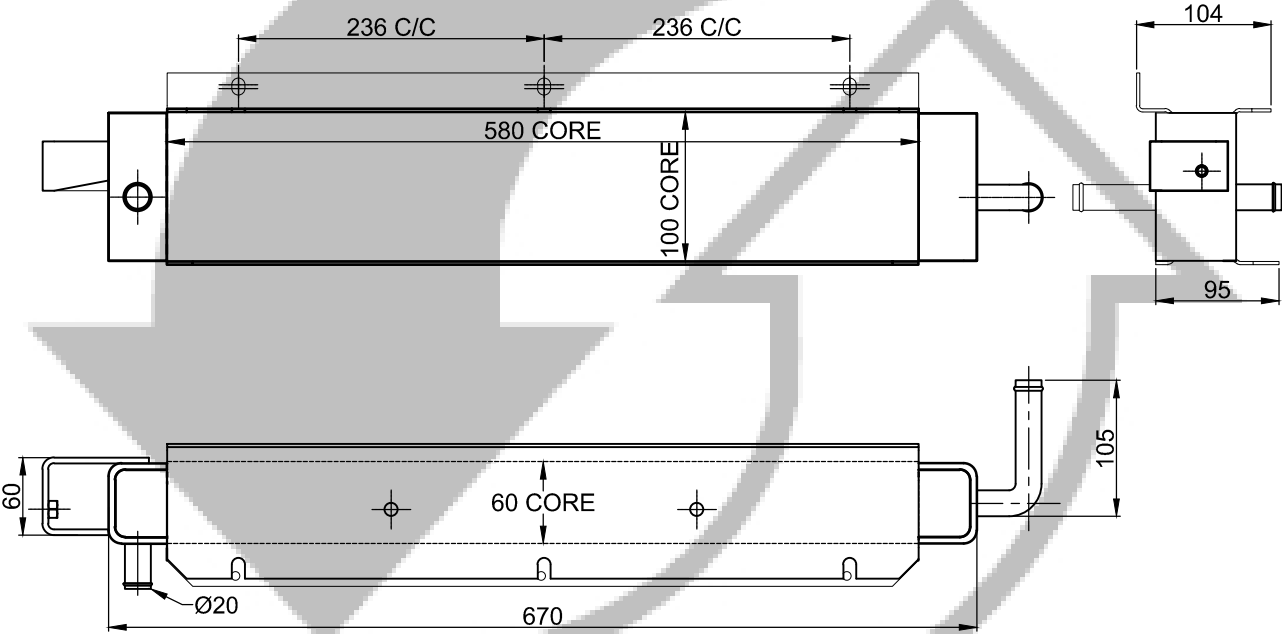

MODEL:JOHN DEERE

PART NUMBER:OIL580JOH1COM

OILCOOLER-LAND ROVER

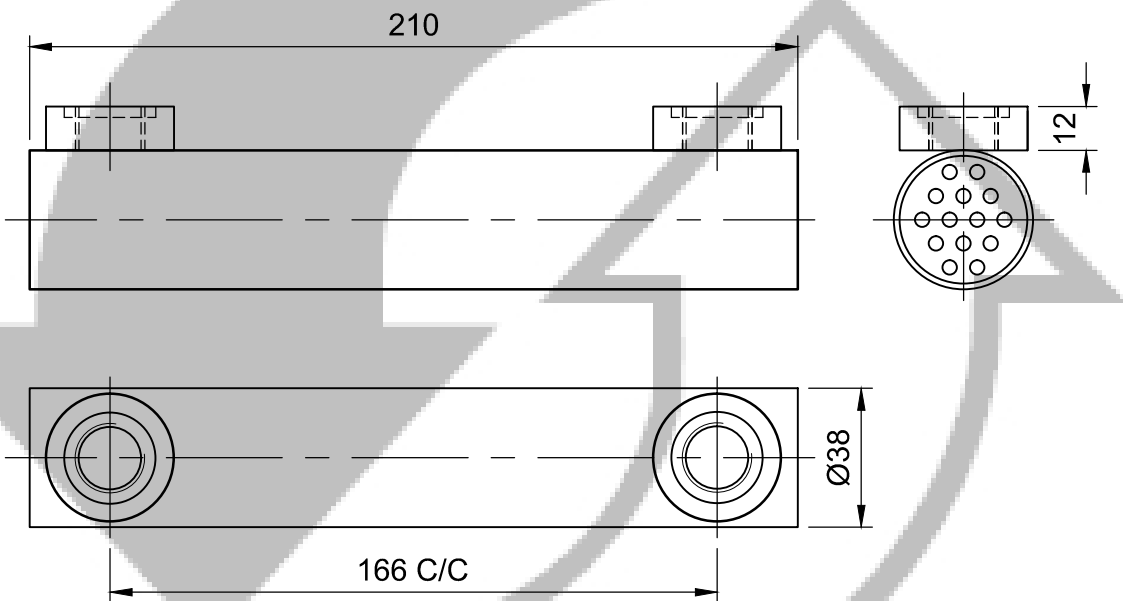

MODEL:LAND ROVER

PART NUMBER:TMOC-210LRO1COM

OILCOOLER-LINDE

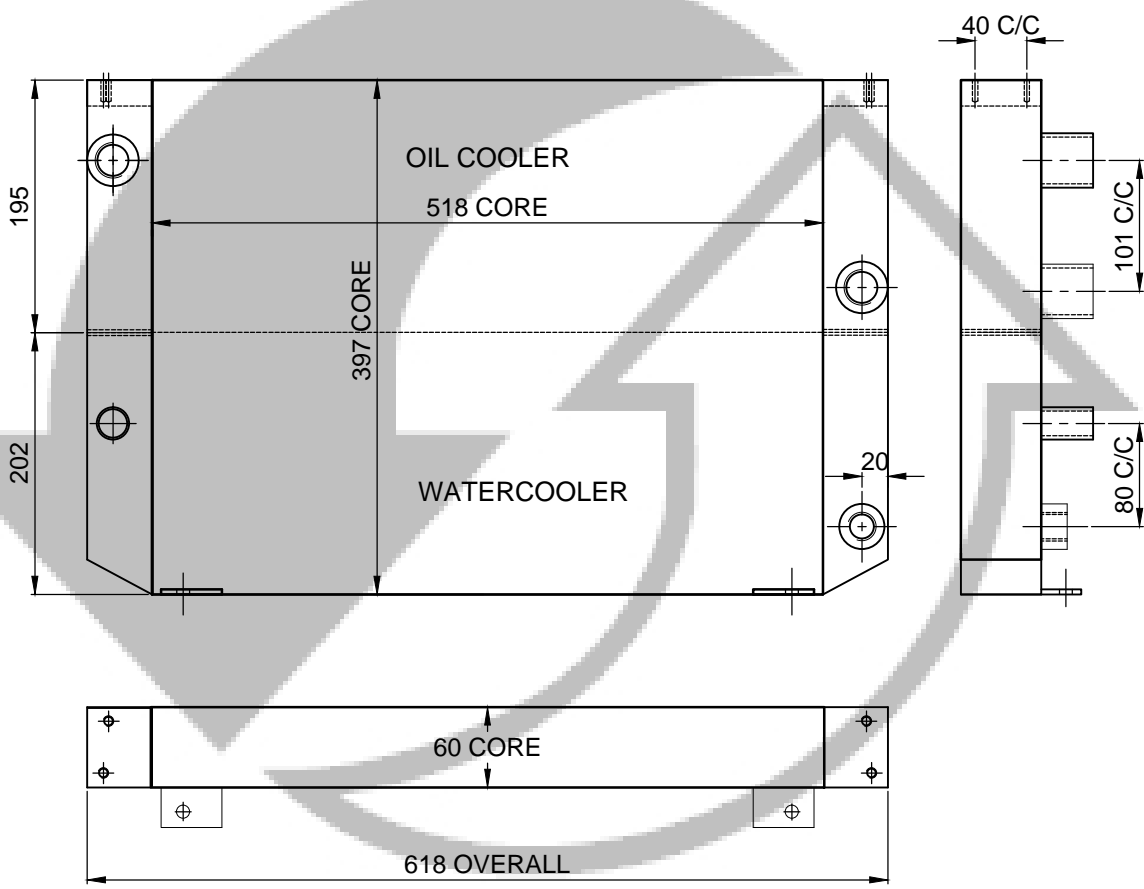

MODEL:LINDE

PART NUMBER:OIL502LIN1COM

OILCOOLER-MAGIRUS

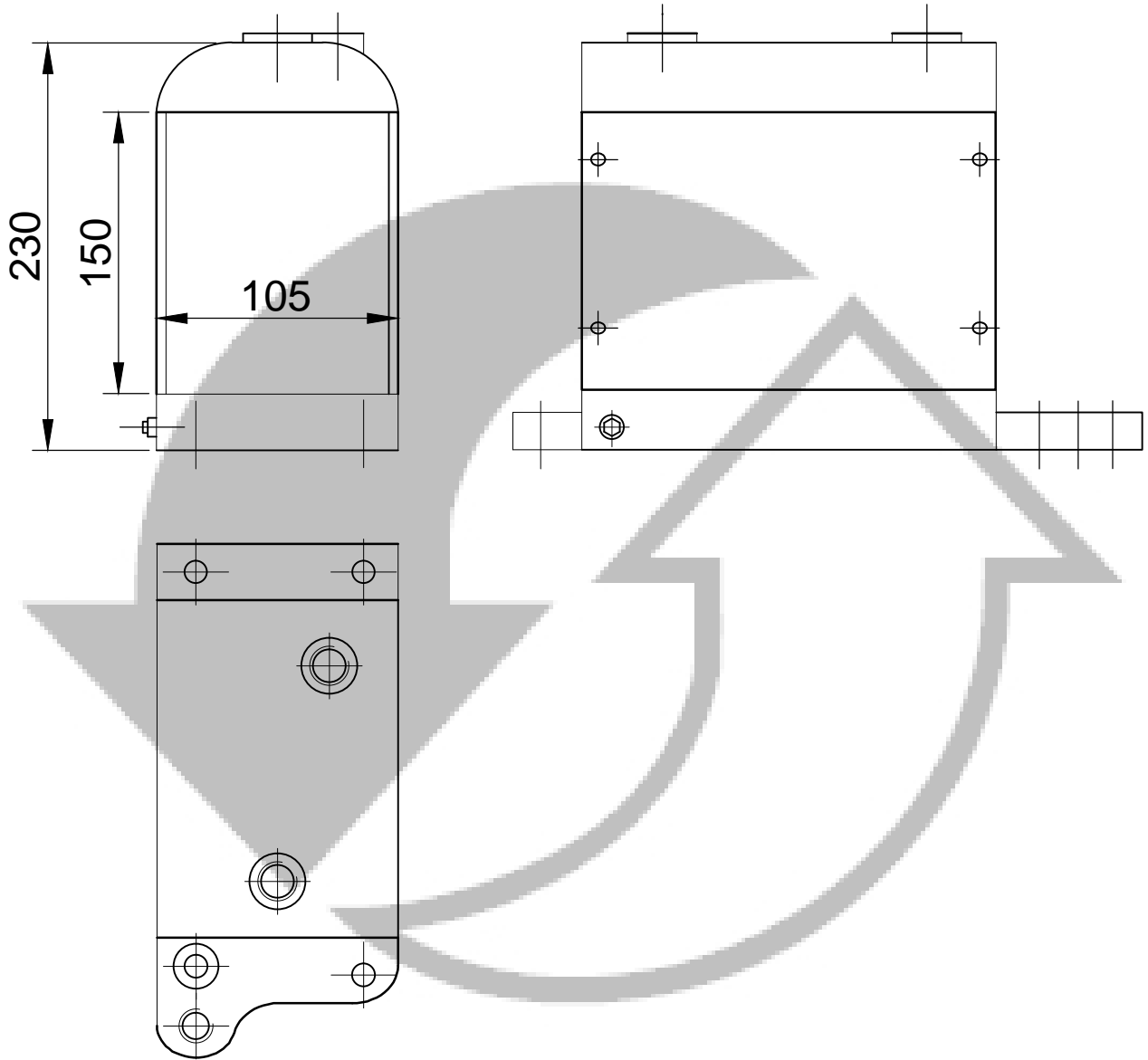

RECORE ONLY



MODEL:MAGIRUS DEUTZ

PART NUMBER:OIL150MAG1COM

OILCOOLER-MAGIRUS

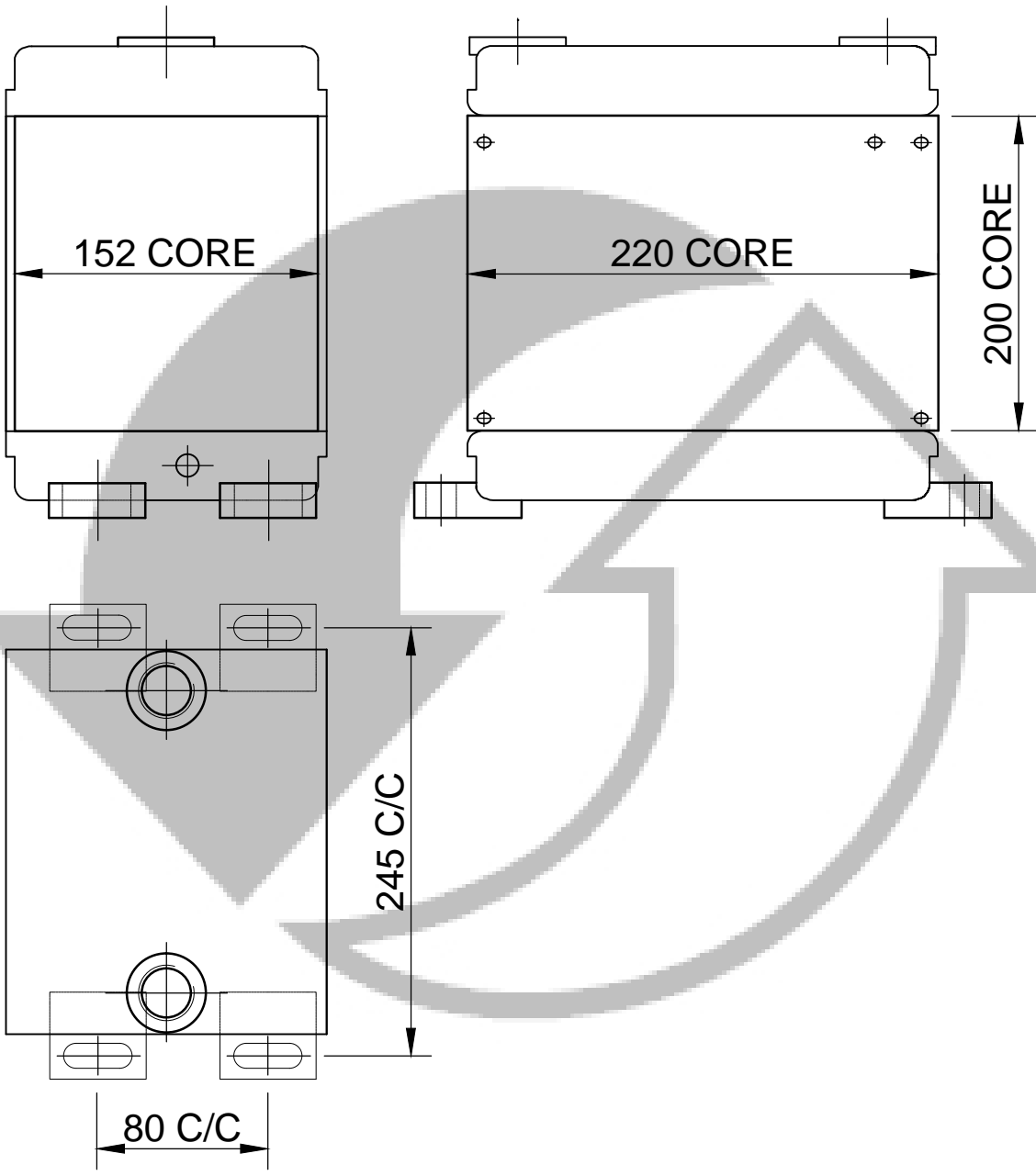

RECORE ONLY



MODEL:MAGIRUS DEUTZ

PART NUMBER:OIL180MAG1COM

OILCOOLER-MAGIRUS

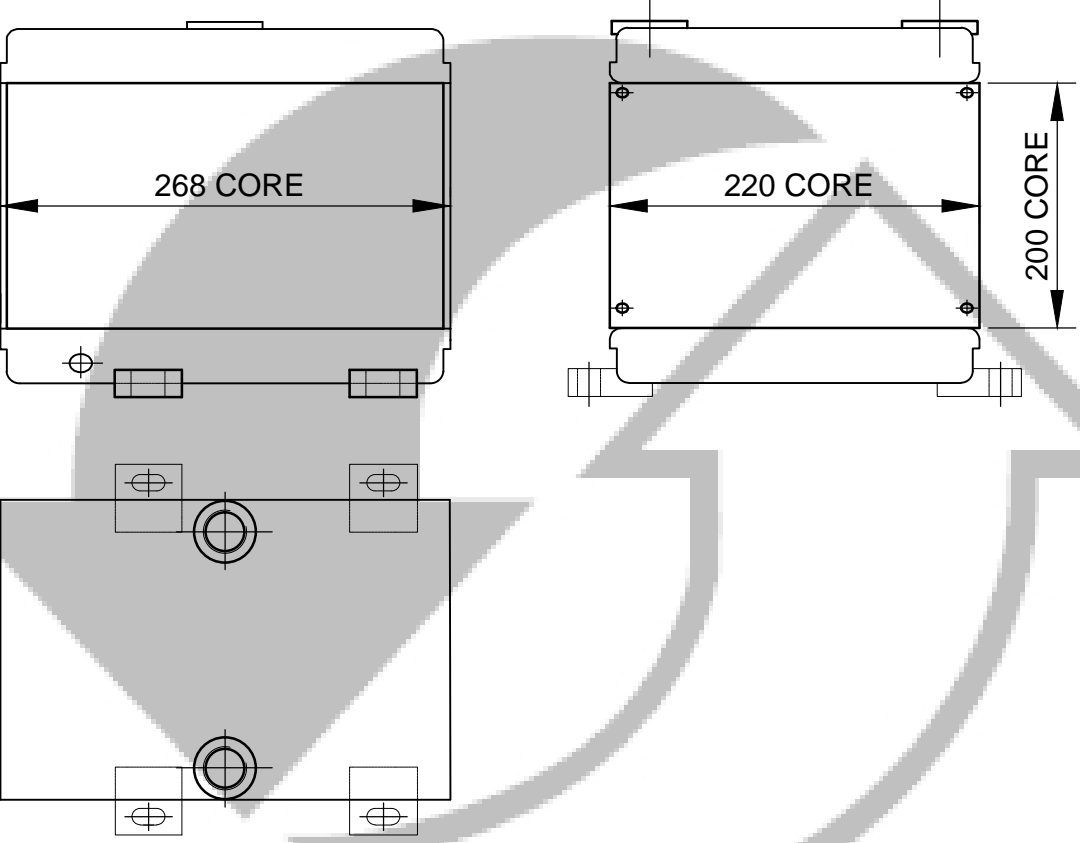

RECORE ONLY



MODEL:MAGIRUS DEUTZ

PART NUMBER:OIL180MAG2COM

OILCOOLER-MAGIRUS

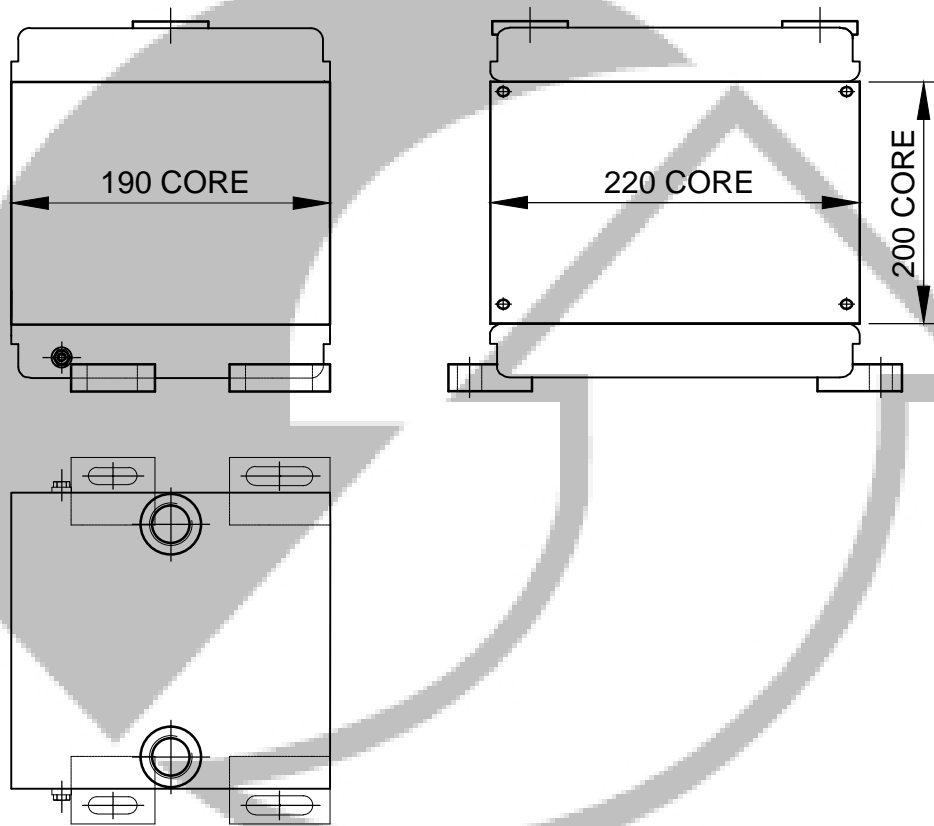

RECORE ONLY



MODEL:MAGIRUS DEUTZ

PART NUMBER:OIL180MAG3COM

OILCOOLER-MAGIRUS

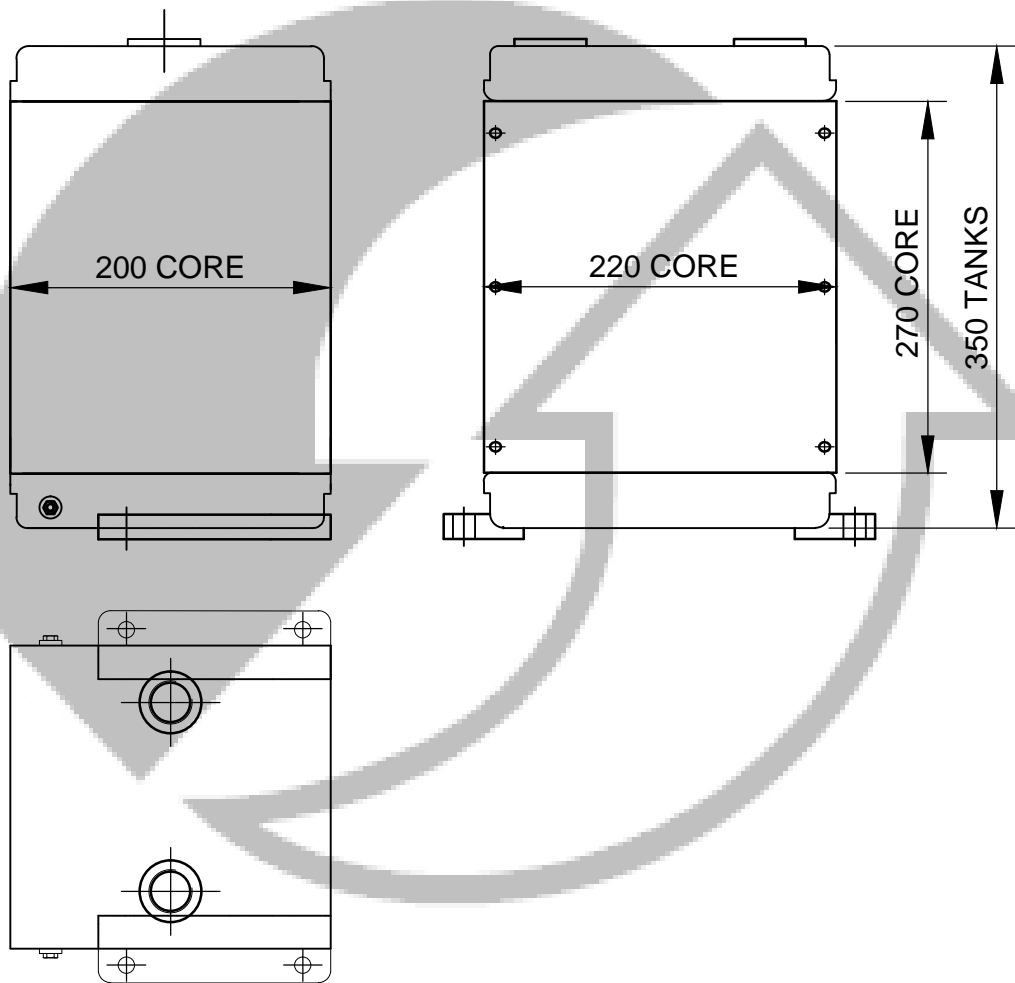

RECORE ONLY



MODEL:MAGIRUS DEUTZ

PART NUMBER:OIL270MAG1COM

OILCOOLER-MAGIRUS

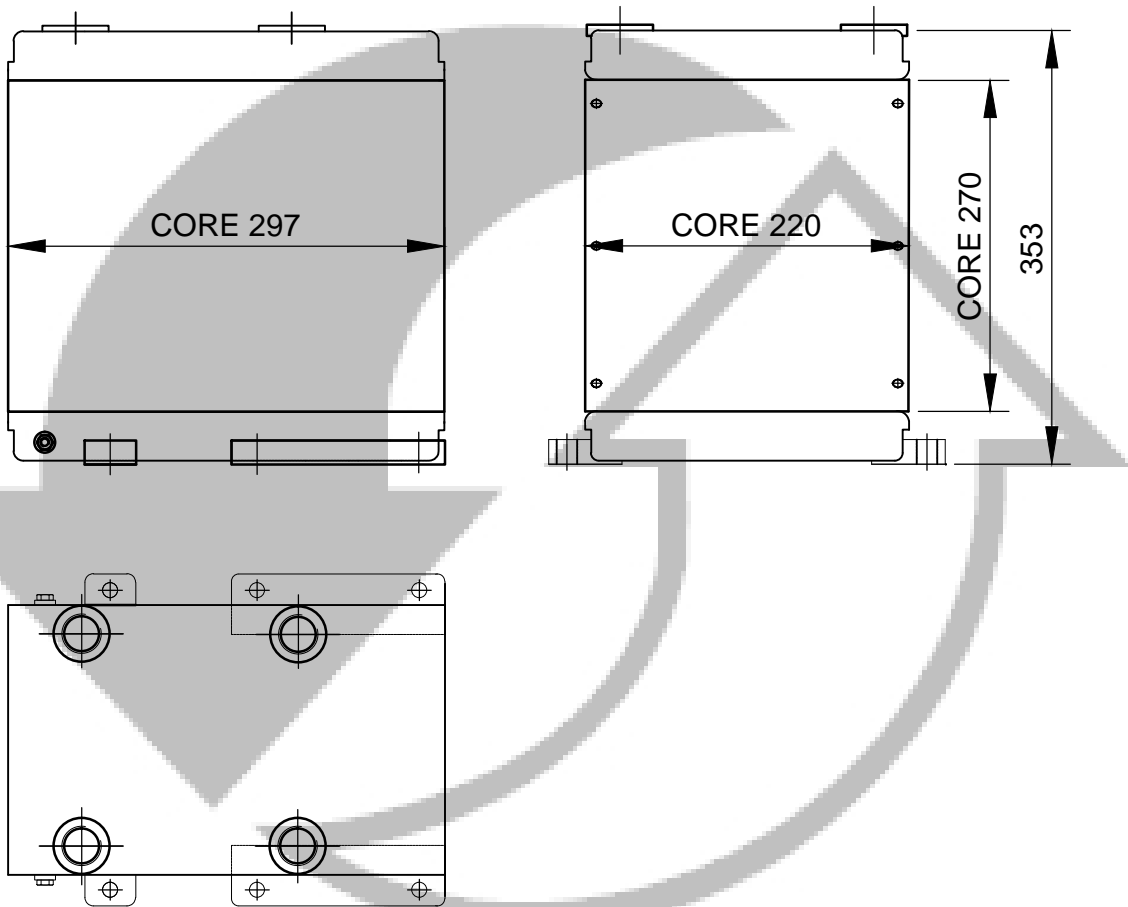

RECORE ONLY



MODEL:MAGIRUS DEUTZ

PART NUMBER:OIL270MAG2COM

OILCOOLER-MAGIRUS

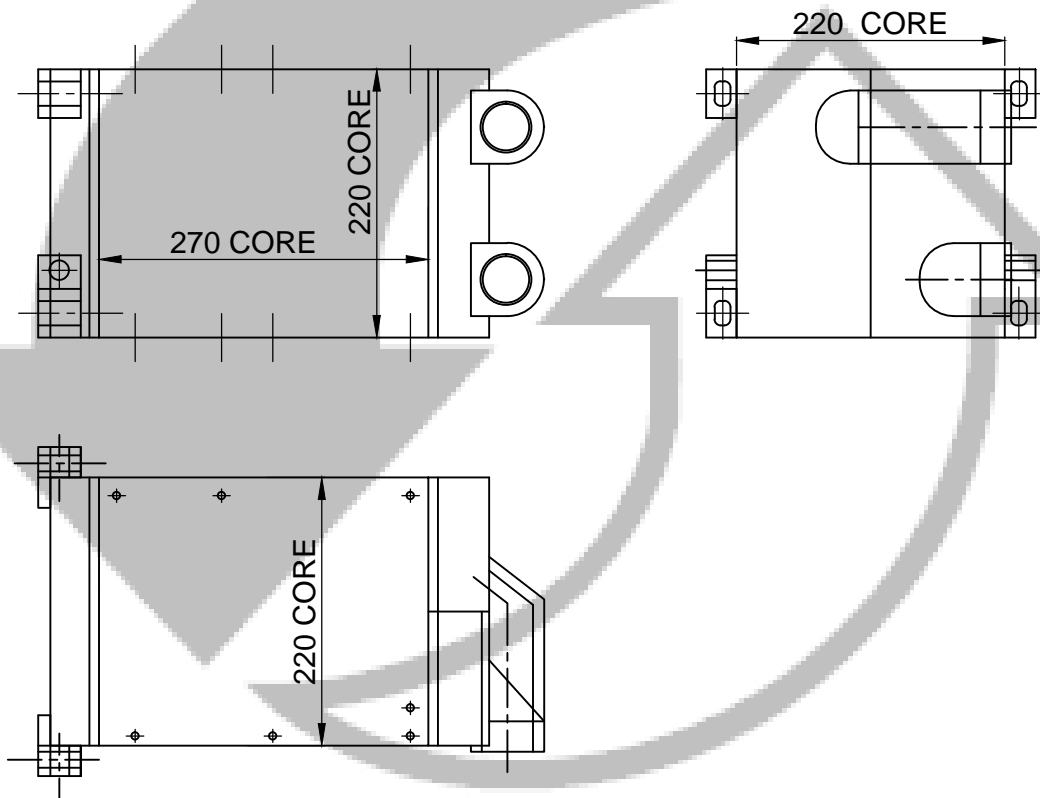

RECORE ONLY



MODEL:MAGIRUS DEUTZ

PART NUMBER:OIL270MAG3COM

OILCOOLER-MAN

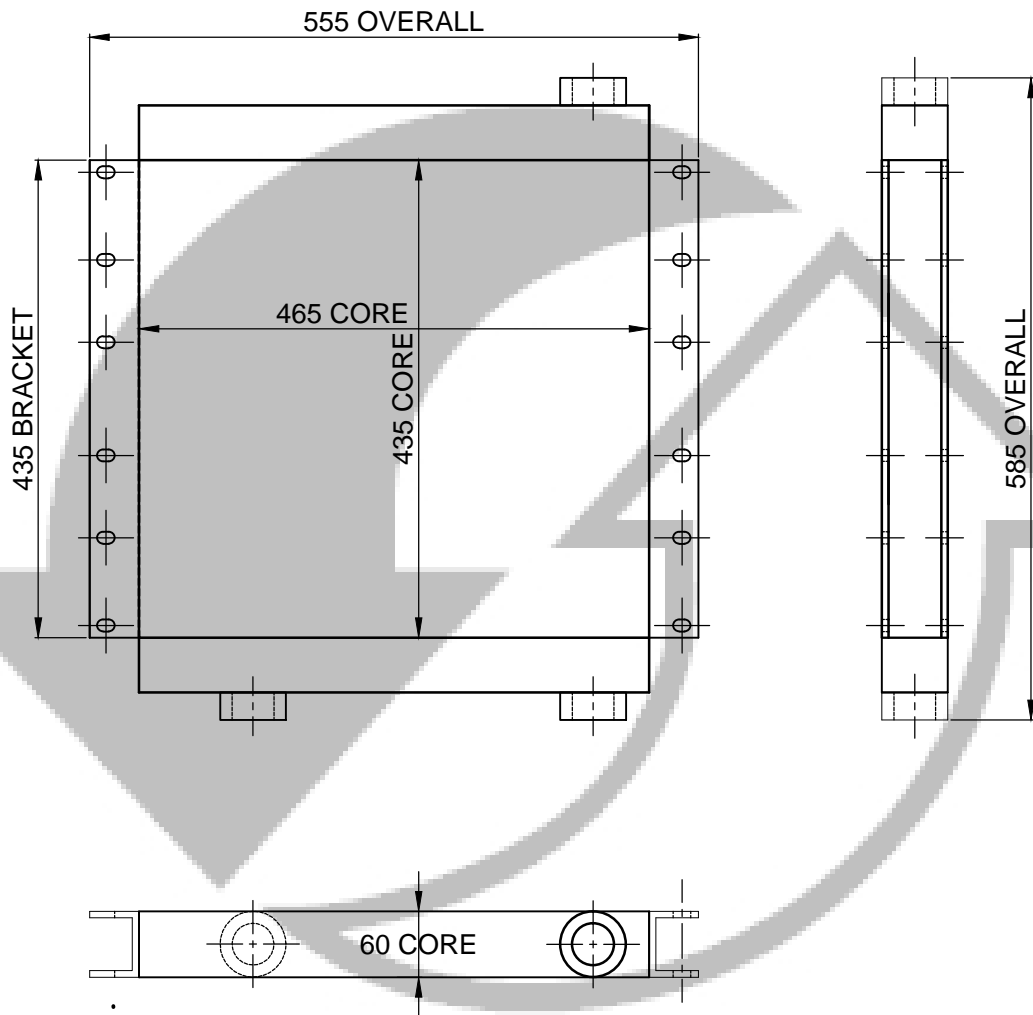

MODEL:MAN

PART NUMBER:OIL419MAN1COM

OILCOOLER-MAN

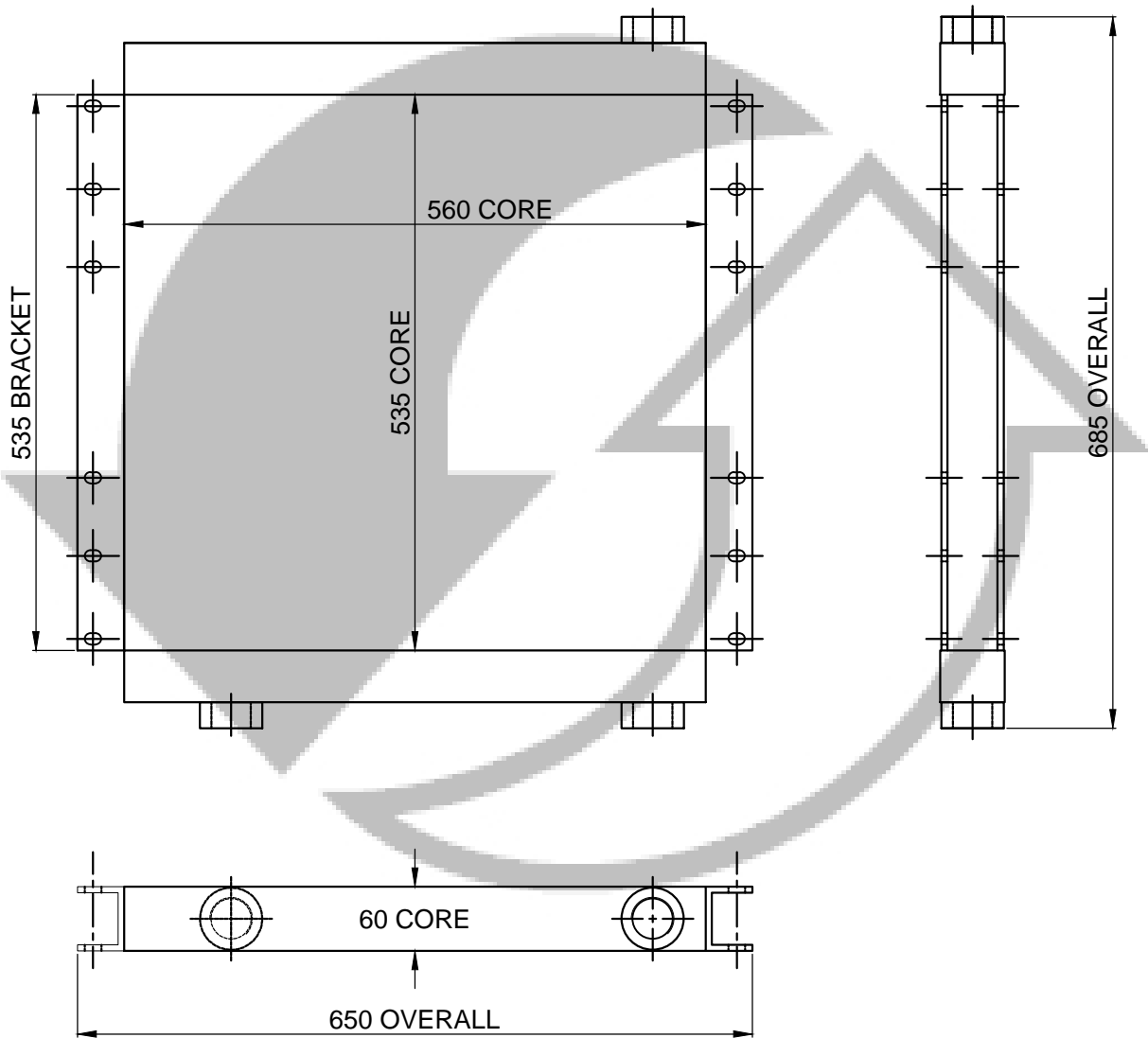

MODEL:MAN

PART NUMBER:OIL519MAN1COM

OILCOOLER-MAN

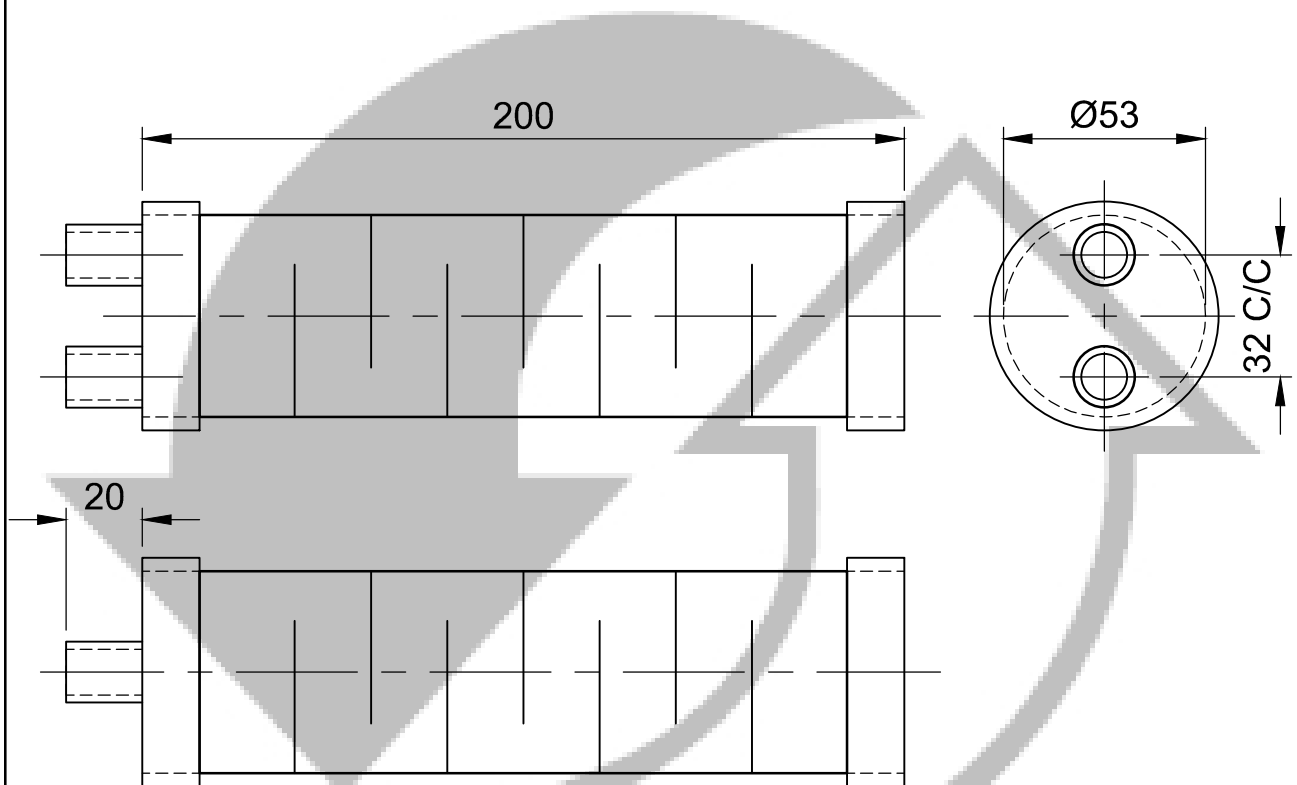

MODEL:MAN

PART NUMBER:TMOC-200MAN1COM

OILCOOLER-MERCEDES BENZ

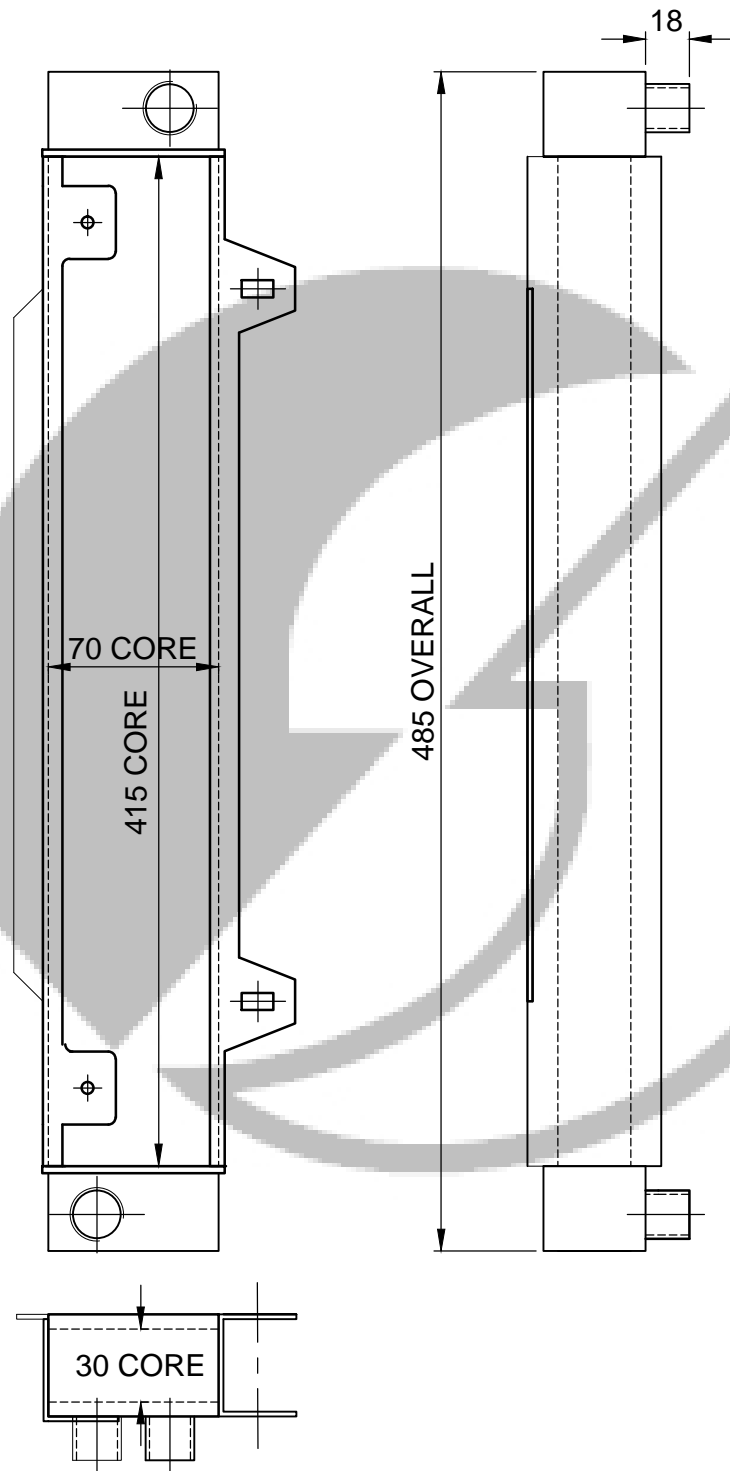

MODEL:MERCEDES BENZ

PART NUMBER:OIL415MER_1COM

OILCOOLER-MERCEDES BENZ

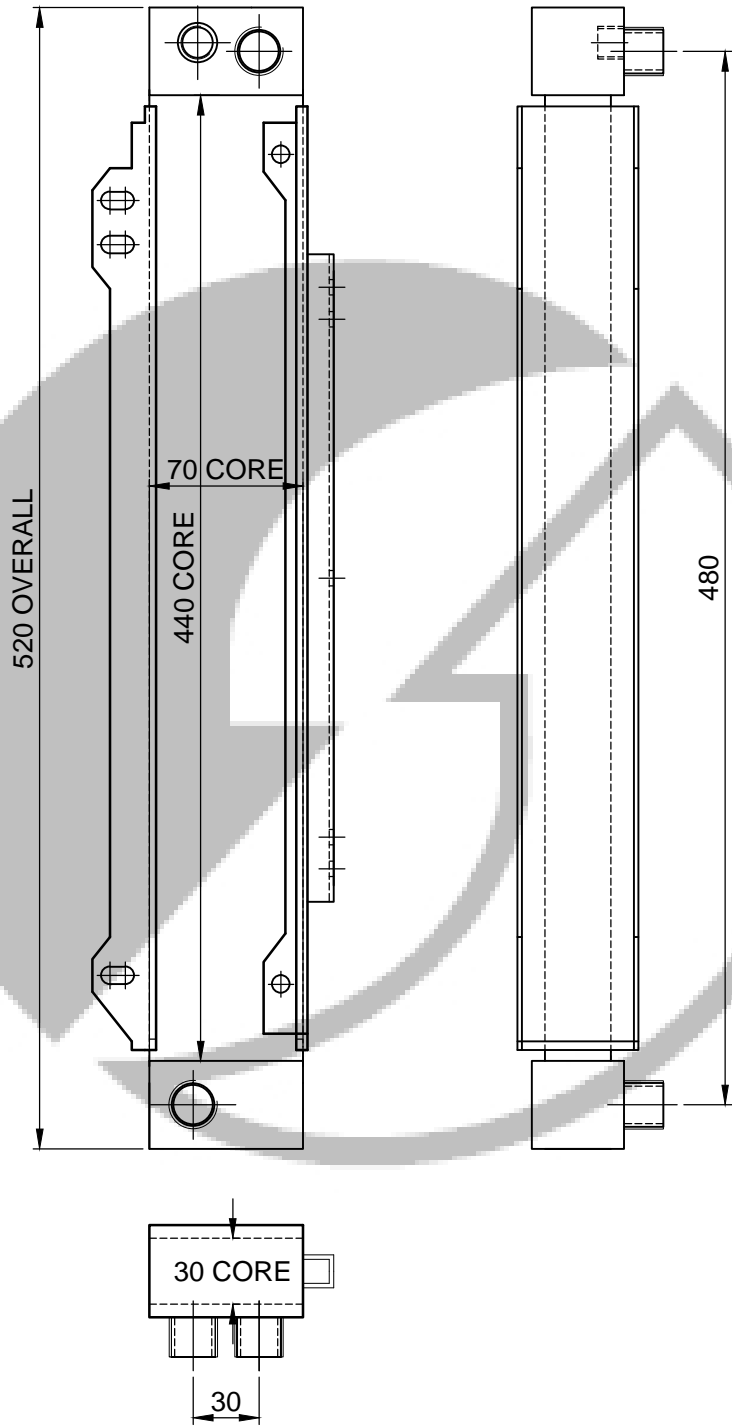

MODEL:MERCEDES BENZ

PART NUMBER:OIL440MER1COM

OILCOOLER-MERCEDES BENZ

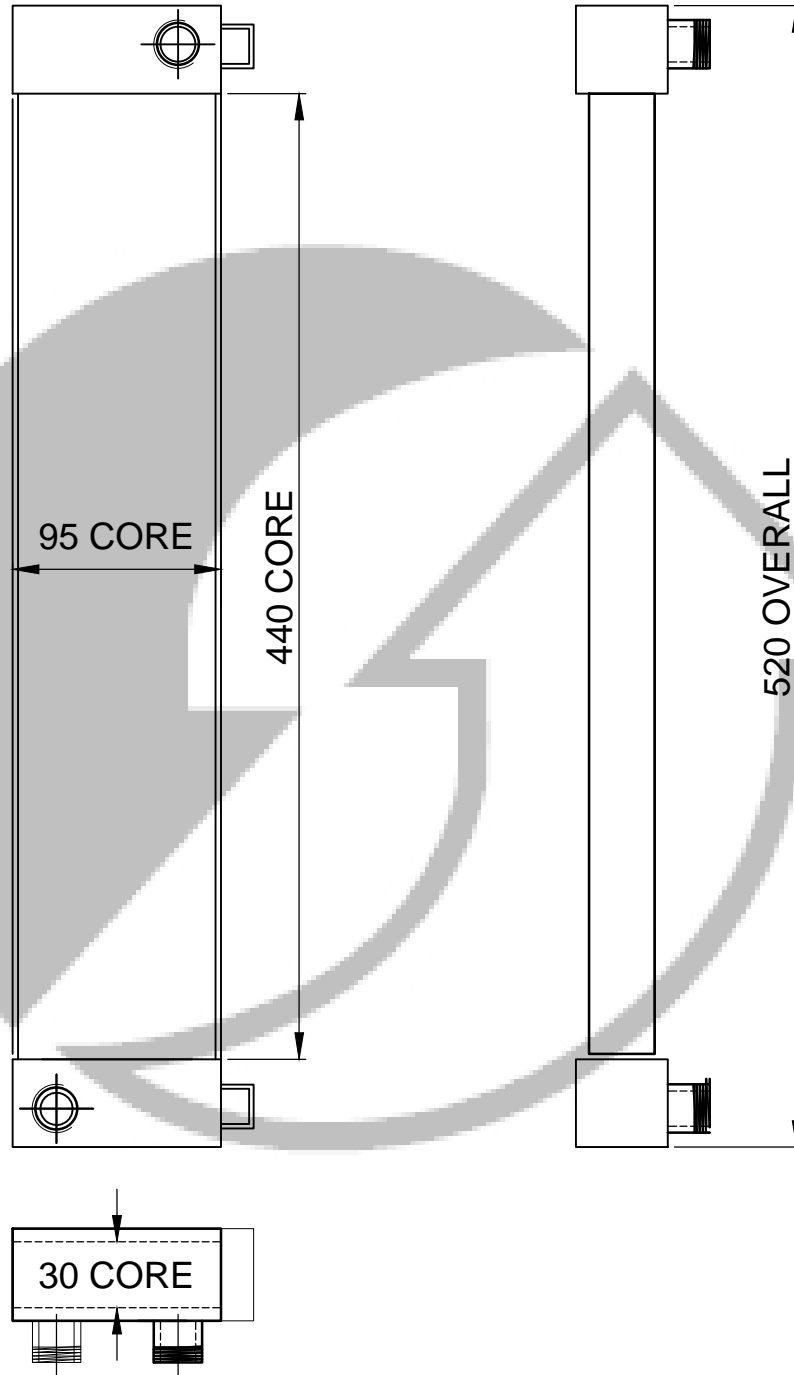

MODEL:MERCEDES BENZ

PART NUMBER:OIL440MER2COM

OILCOOLER-MERCEDES BENZ

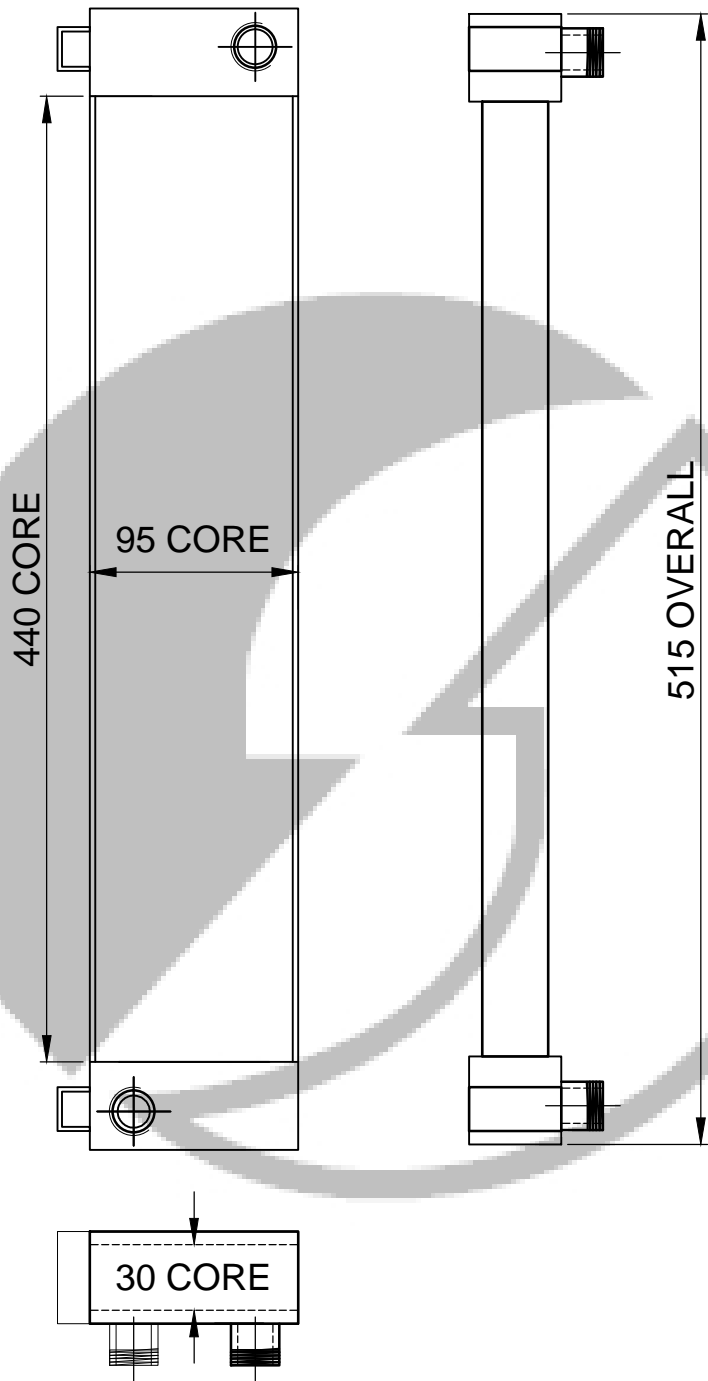

MODEL:MERCEDES BENZ

PART NUMBER:OIL440MER3COM

OILCOOLER-MERCEDES BENZ

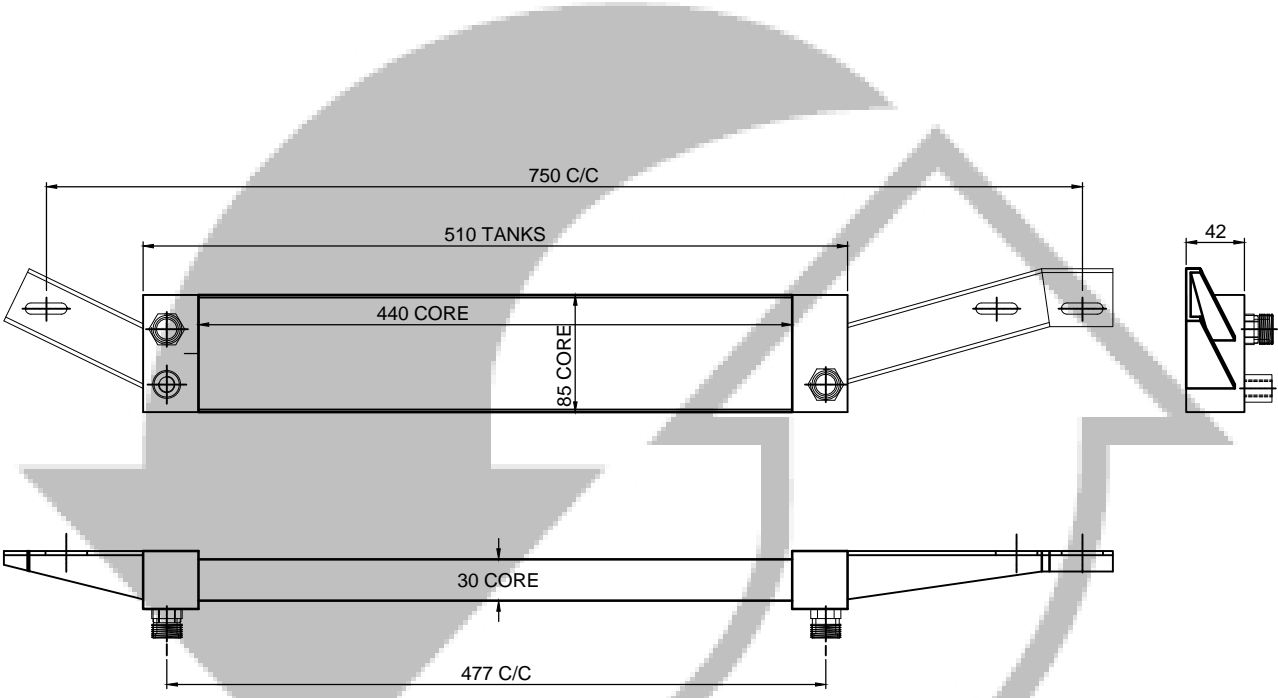

MODEL:MERCEDES BENZ

PART NUMBER:OIL440MER4COM

OILCOOLER-MERCEDES BENZ

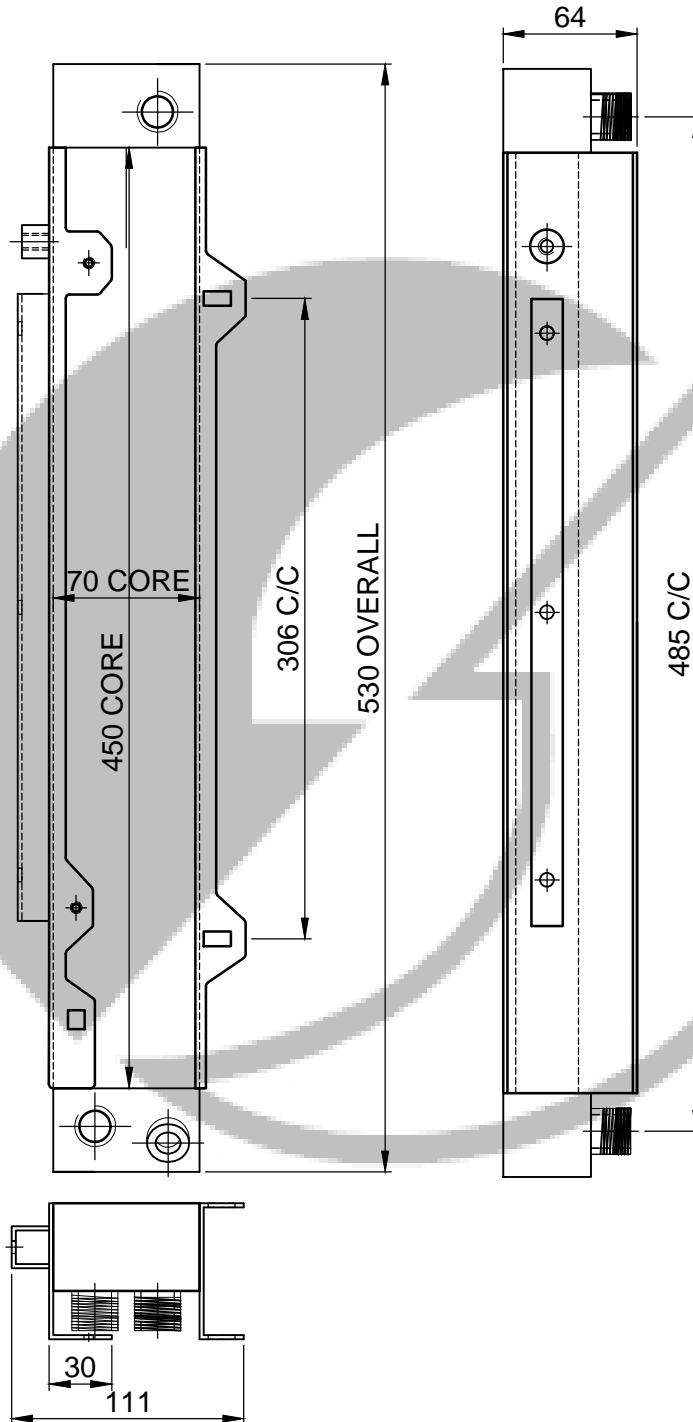

MODEL:MERCEDES BENZ

PART NUMBER:OIL450MER1COM

OILCOOLER-MERCEDES BENZ

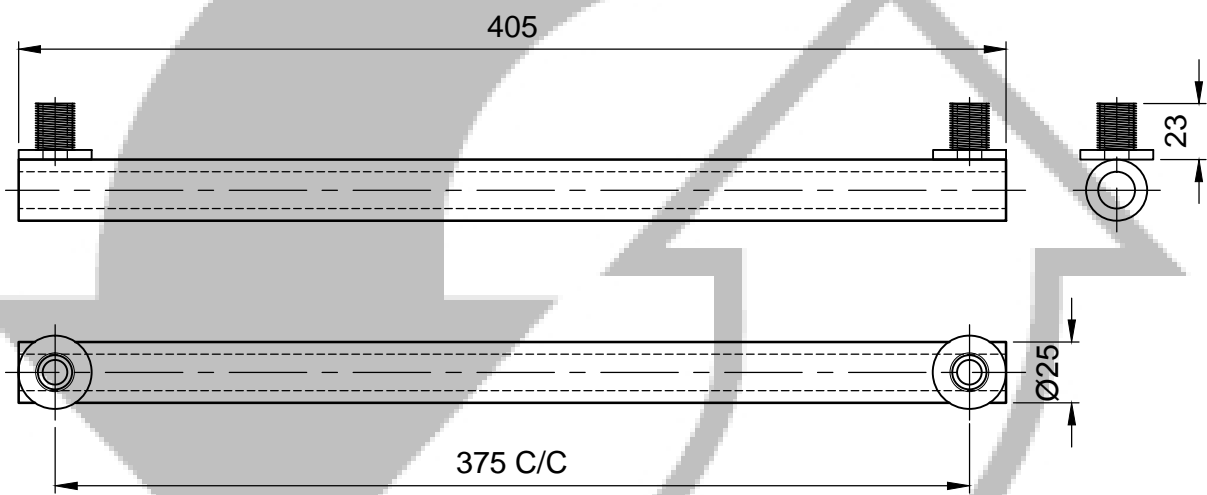

MODEL:MERCEDES BENZ

PART NUMBER:TMOC-DB405MER1COM

OILCOOLER-MERCEDES BENZ

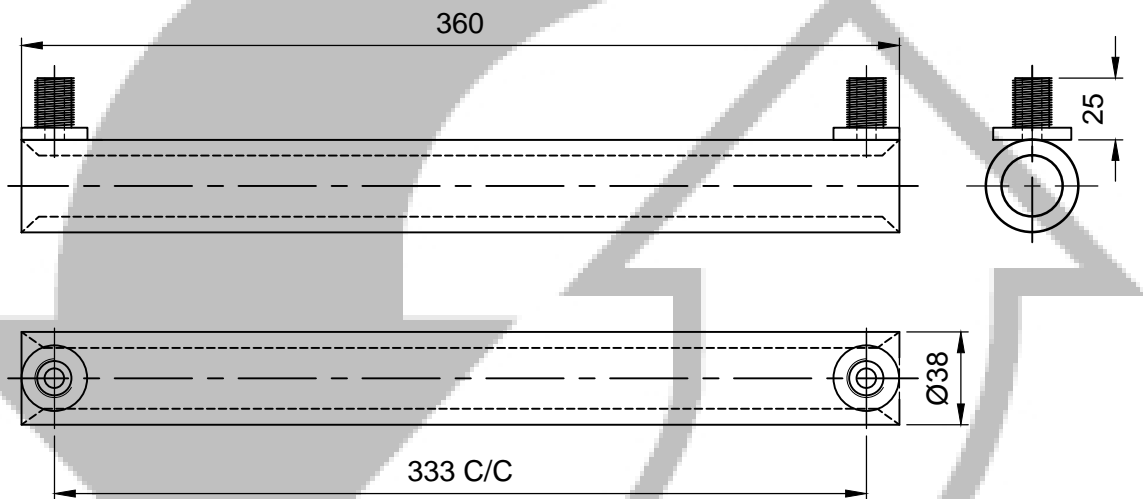

MODEL:MERCEDES BENZ

PART NUMBER:TMOC-DB360MER

OILCOOLER-MERCEDES BENZ

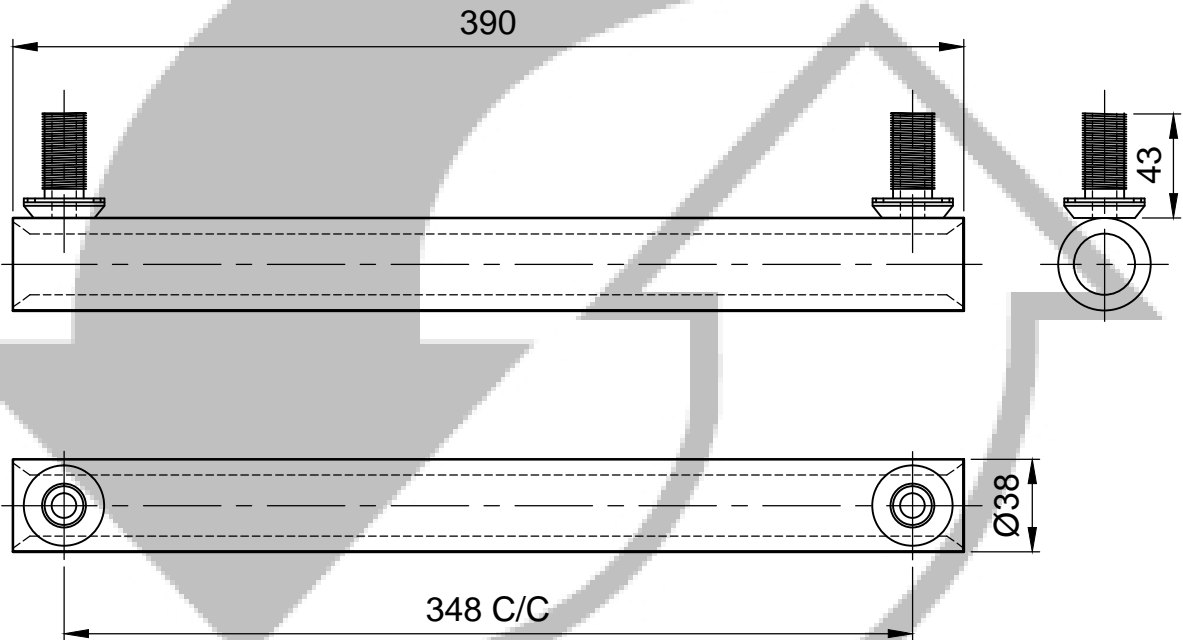

MODEL:MERCEDES BENZ

PART NUMBER:TMOC-DB390MER SCREW ON

OILCOOLER-MERCEDES BENZ

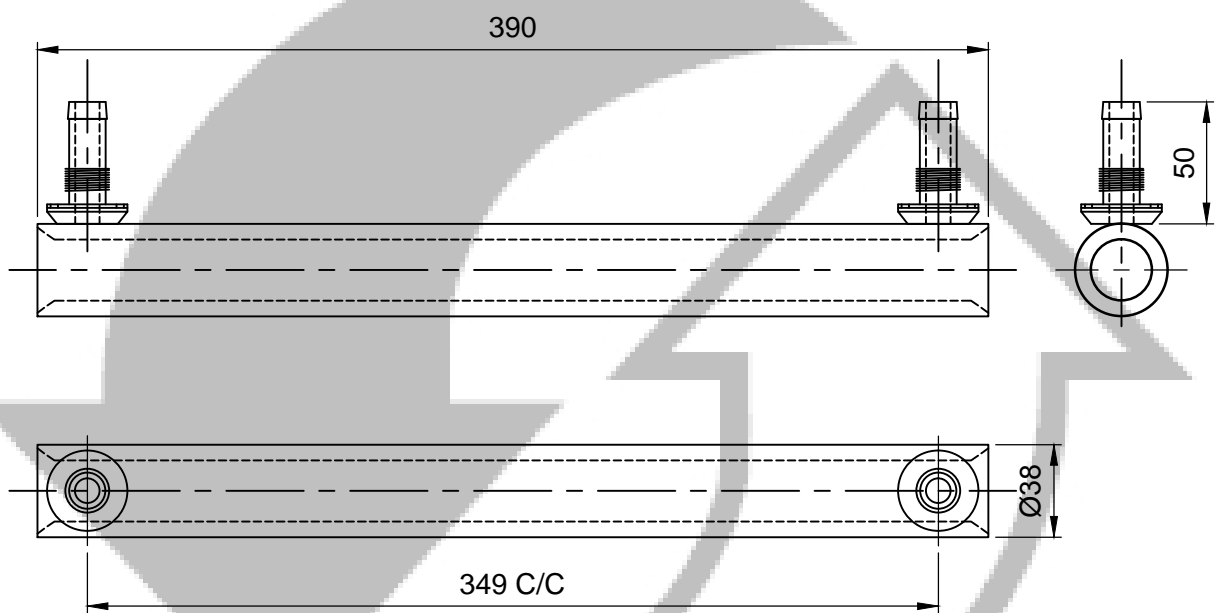

MODEL:MERCEDES BENZ

PART NUMBER:TMOC-DB390MER CLIP-ON

OILCOOLER-MERCEDES BENZ

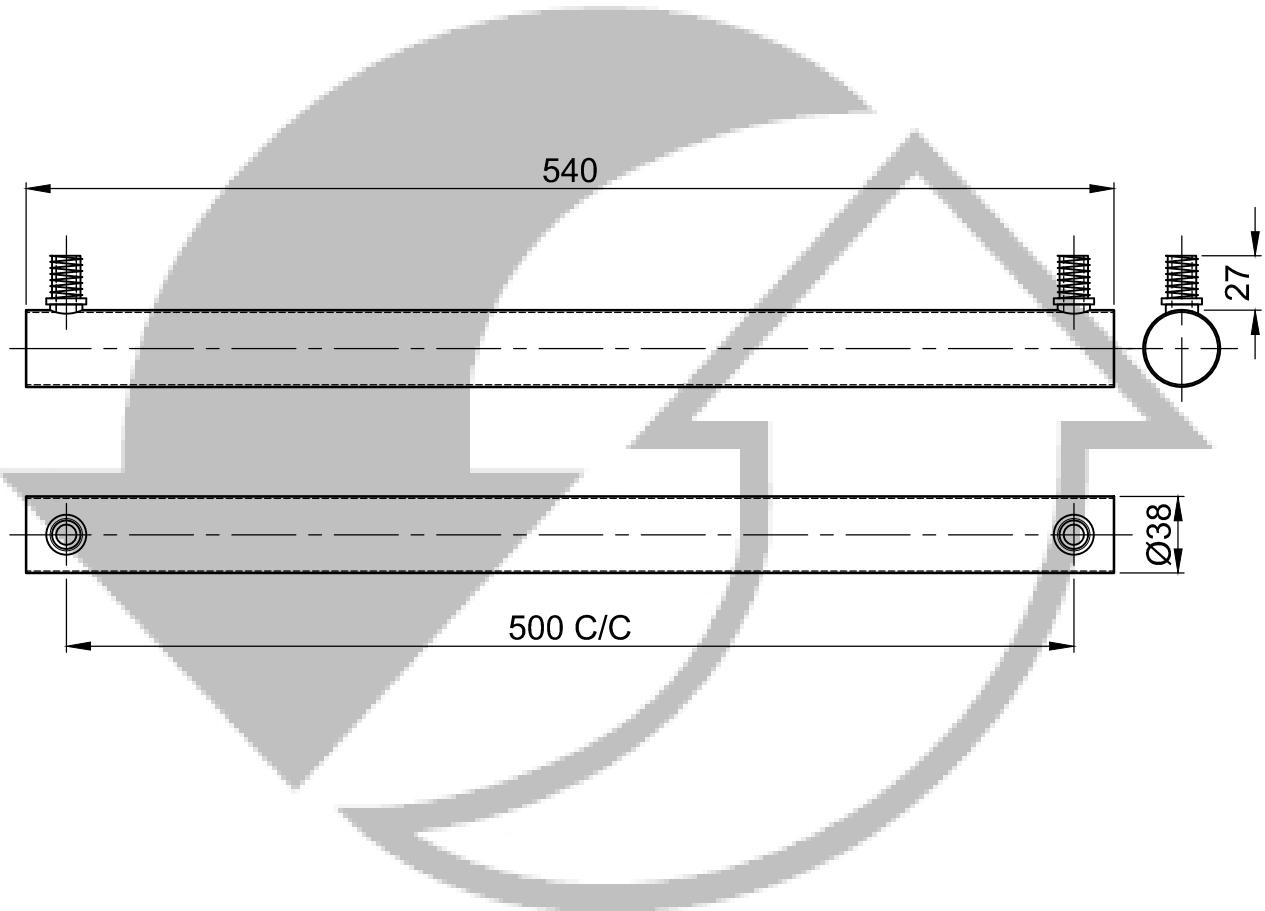

MODEL:MERCEDES BENZ_ACTROS

PART NUMBER:TMOC-DB540MER1COM

OILCOOLER-NISSAN

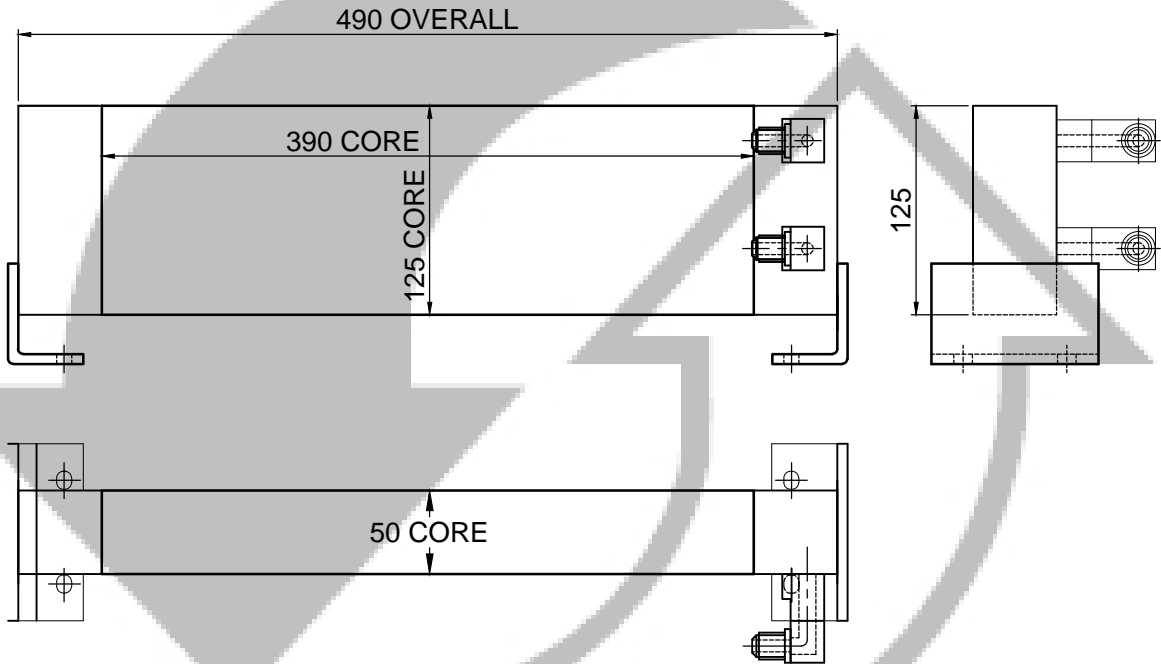

MODEL:NISSAN

PART NUMBER:OIL394NIS1COM

OILCOOLER-TUBE AND SHELL

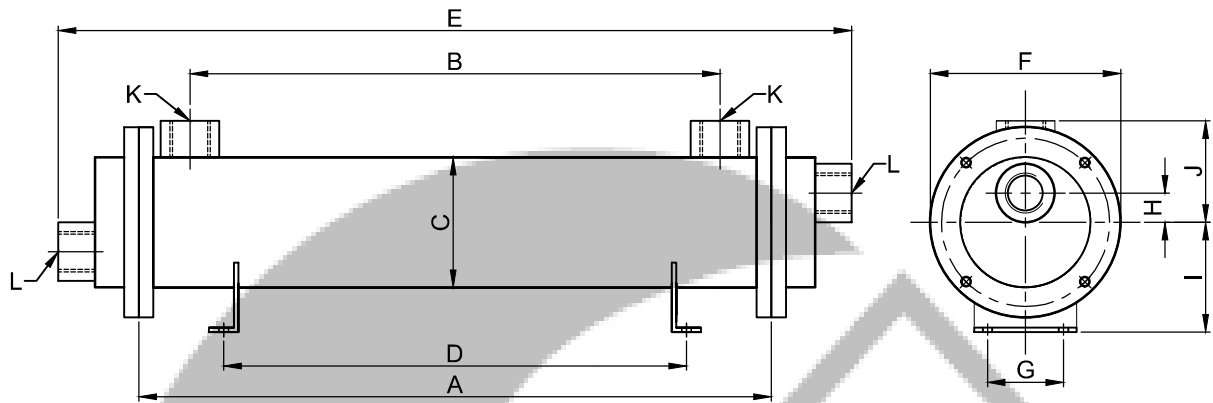

Model	# Tubes	A	B	C	D	E	F	G	H	I	J	K & L
83/210	65	210	140	89	104	320	130	52	20	71	69	3/4"
83/300	65	300	226	89	190	410	130	52	20	71	69	3/4"
83/400	65	400	324	89	288	510	130	52	20	71	69	3/4"
83/525	65	525	452	89	416	635	130	52	20	71	69	3/4"
108S/280	117	280	202	114	190	400	165	76	25	93	83	1"
108S/380	117	380	300	114	288	500	165	76	25	93	83	1"
108S/510	117	510	428	114	288	630	165	76	25	93	83	1"
108S/650	117	650	574	114	434	770	165	76	25	93	83	1"
108L/380	123	380	294	114	190	500	165	76	25	93	83	1 1/4"
108L/510	123	510	422	114	318	630	165	76	25	93	83	1 1/4"
108L/650	123	650	568	114	464	770	165	76	25	93	83	1 1/4"
108L/840	123	840	746	114	642	960	165	76	25	93	83	1 1/4"
135/370	197	370	272	141	108	510	215	120	38	117	108	1 1/2"
135/650	197	650	546	141	382	790	215	120	38	117	108	1 1/2"
135/830	197	830	724	141	560	970	215	120	38	117	108	1 1/2"
135/1030	197	1030	926	141	762	1170	215	120	38	117	108	1 1/2"



MODEL:TUBE AND SHELL/SB RANGE

PART NUMBER: SB83 TO SB135

OILCOOLER-SUZUKI

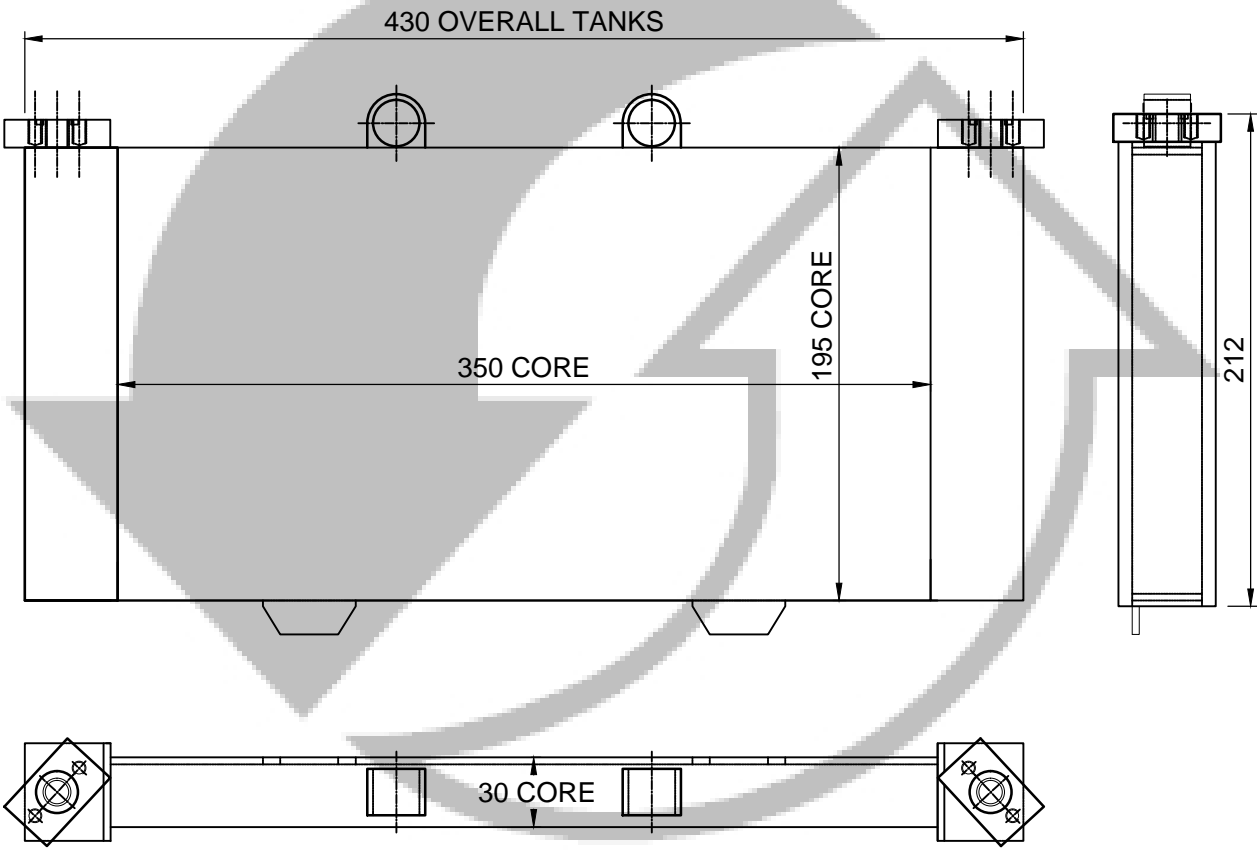

MODEL:SUZUKI

PART NUMBER:OIL356SUZ1COM

OILCOOLER-SUZUKI

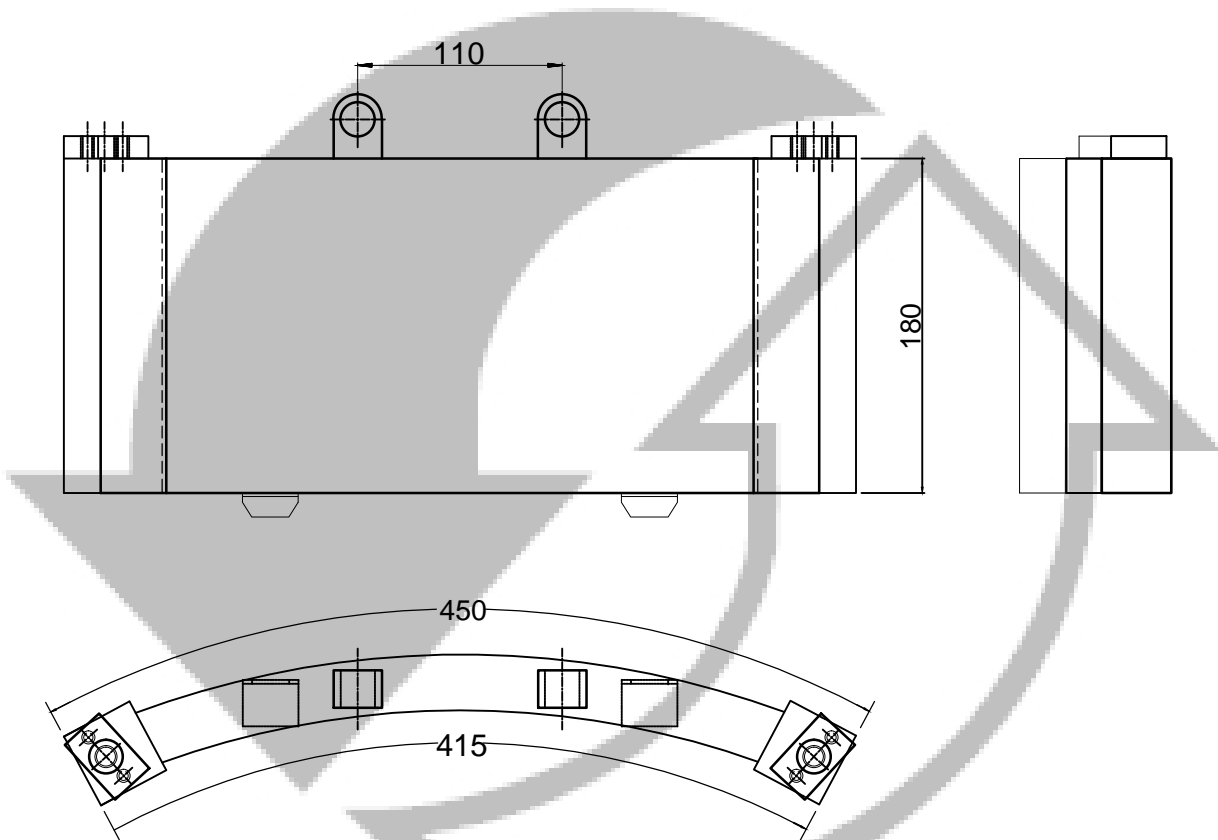

MODEL:SUZUKI

PART NUMBER:OIL368SUZ1COM

OILCOOLER-TOYOTA

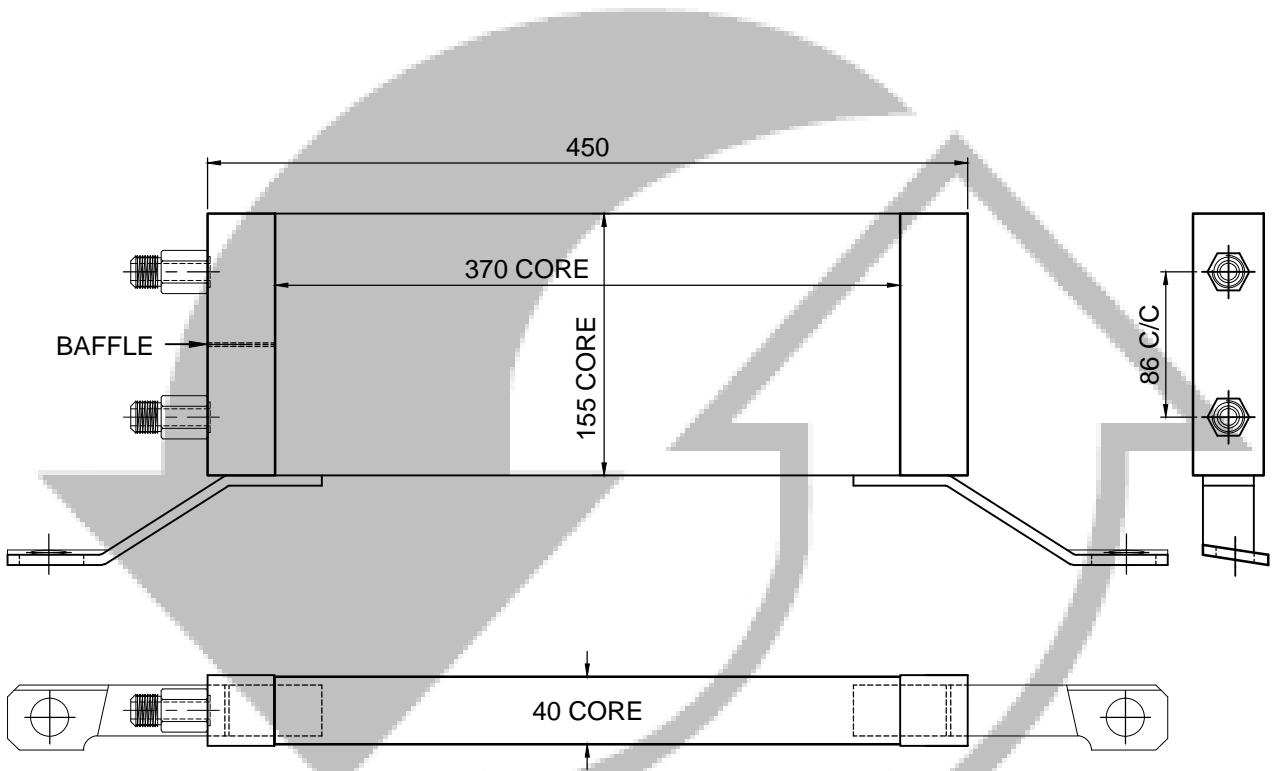

MODEL:TOYOTA

PART NUMBER:OIL400TOY1COM

OILCOOLER-ZIP COOLER

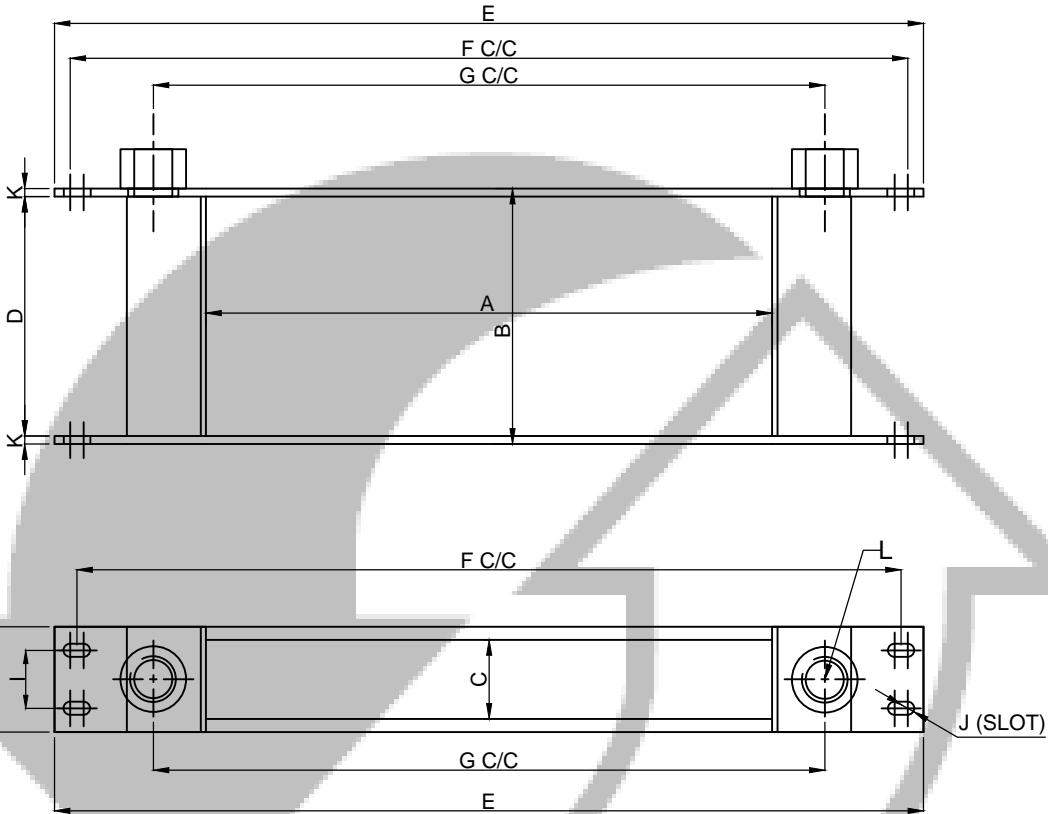

MODEL	A	B	C	D	E	F	G	H	I	J (SLOT)	K	L
ZIP3	215	60	30	54	330	312	248	42	22	Ø5 X 10	3	3/8NPT X 18TPI
ZIP5	215	80	30	74	330	312	248	42	22	Ø5 X 10	3	3/8NPT X 18TPI
ZIP7	215	96	30	90	330	312	248	42	22	Ø5 X 10	3	3/8NPT X 18TPI
ZIP9	215	125	30	119	330	312	248	42	22	Ø5 X 10	3	3/8NPT X 18TPI
ZIP11	215	150	30	144	330	312	248	42	22	Ø5 X 10	3	3/8NPT X 18TPI
ZIP13	215	167	30	161	330	312	248	42	22	Ø5 X 10	3	3/8NPT X 18TPI
ZIP15	215	200	30	194	330	312	248	42	22	Ø5 X 10	3	3/8NPT X 18TPI



MODEL:ZIP COOLER

PART NUMBER:

RADIATORS

RADIATOR-AUSTIN

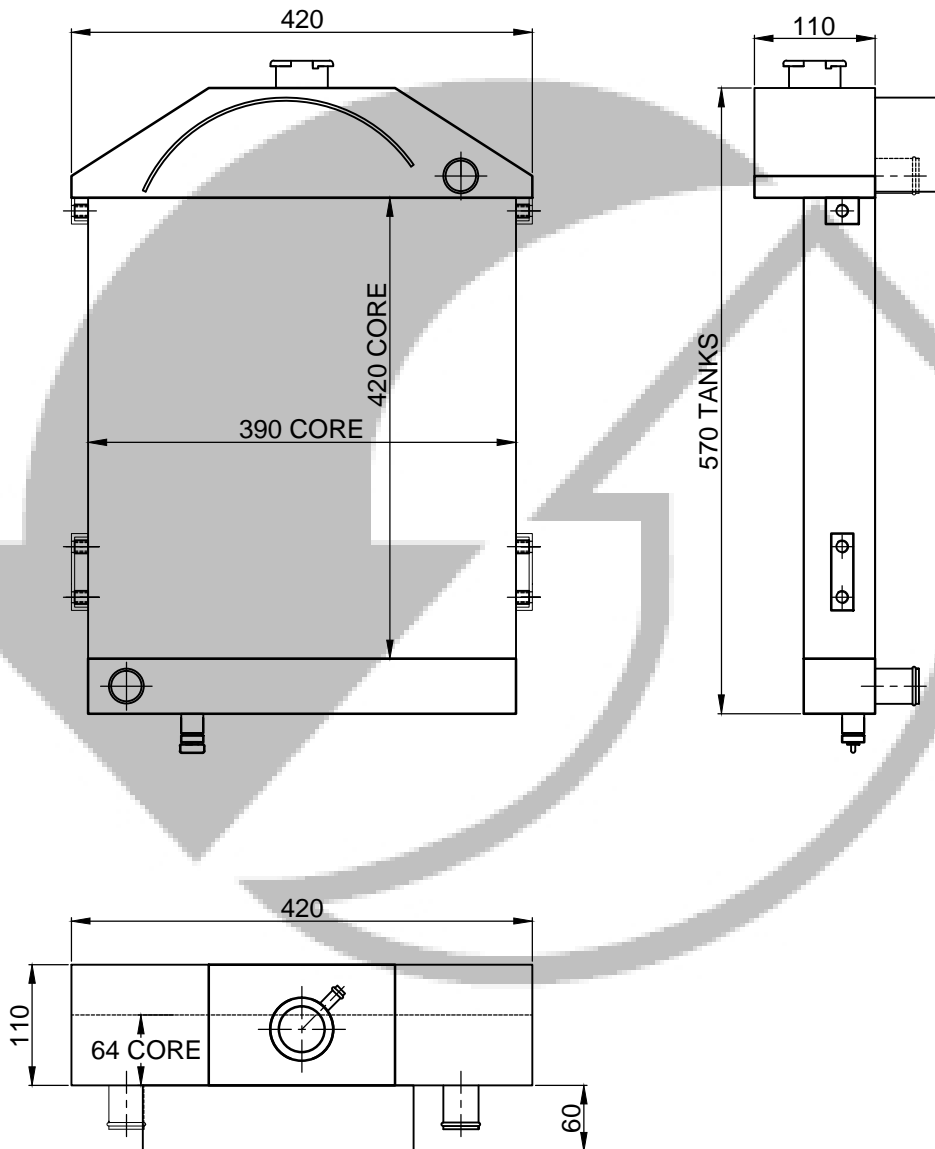

MODEL:AUSTIN HEALEY 100/6 AND 3000

PART NUMBER:RAD420AUS1COM

RADIATOR-BELL

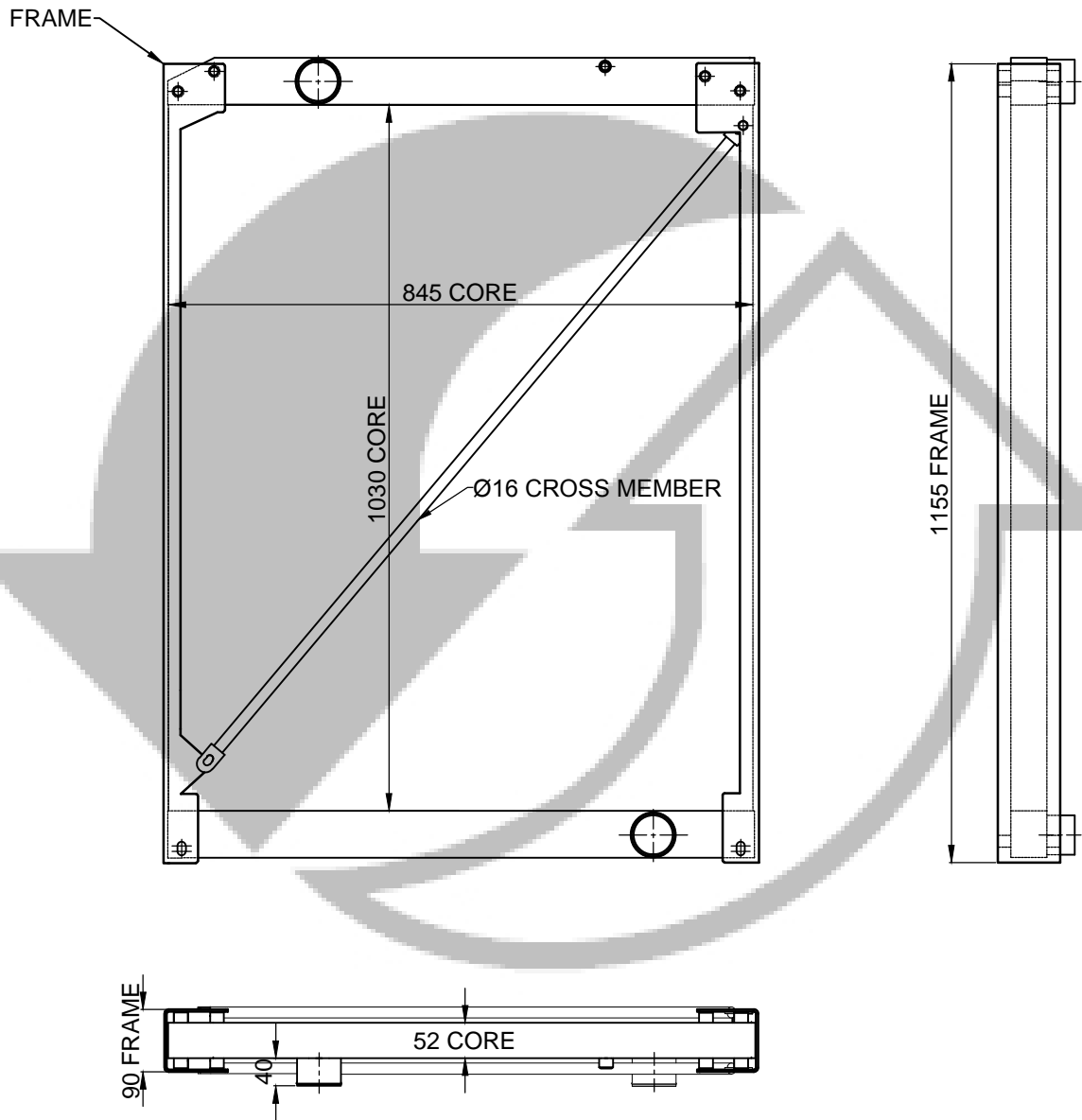

MODEL: BELL DUMPER

PART NUMBER: RAD1030BEL1COM

RADIATOR-FREIGHTLINER

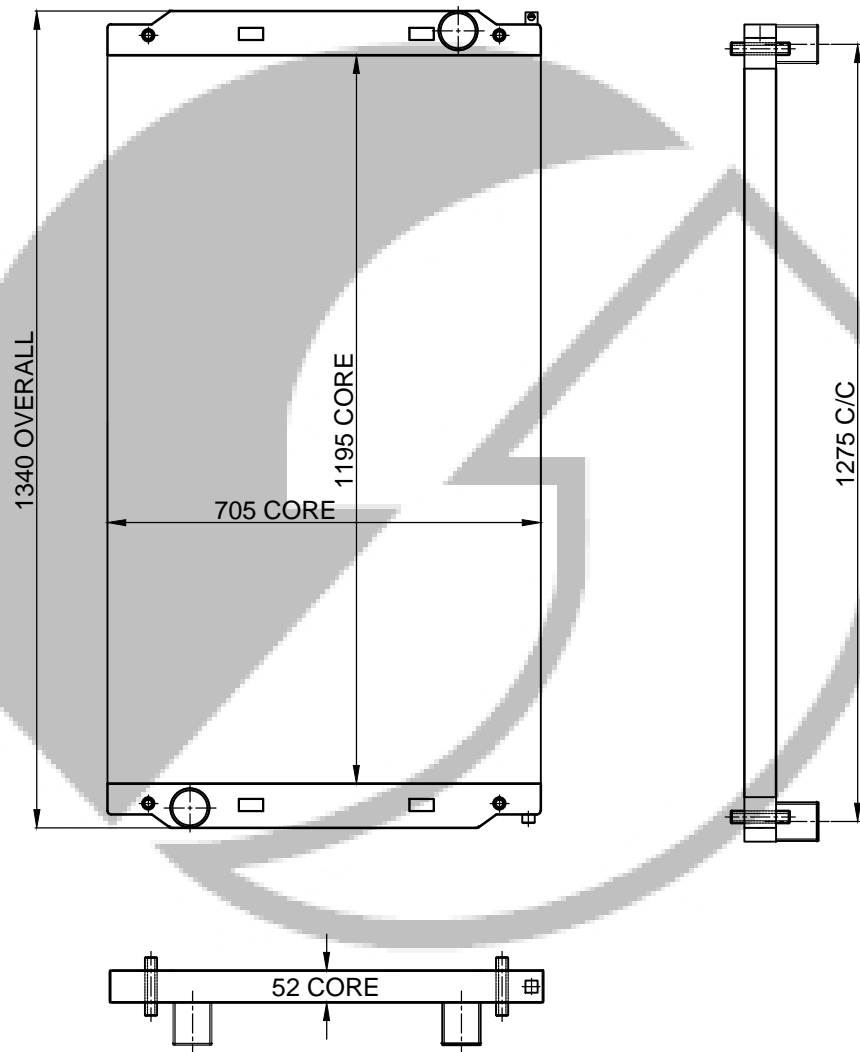

MODEL:FREIGHTLINER ARGOSY

PART NUMBER:RAD1195FR1COM

RADIATOR-HITACHI

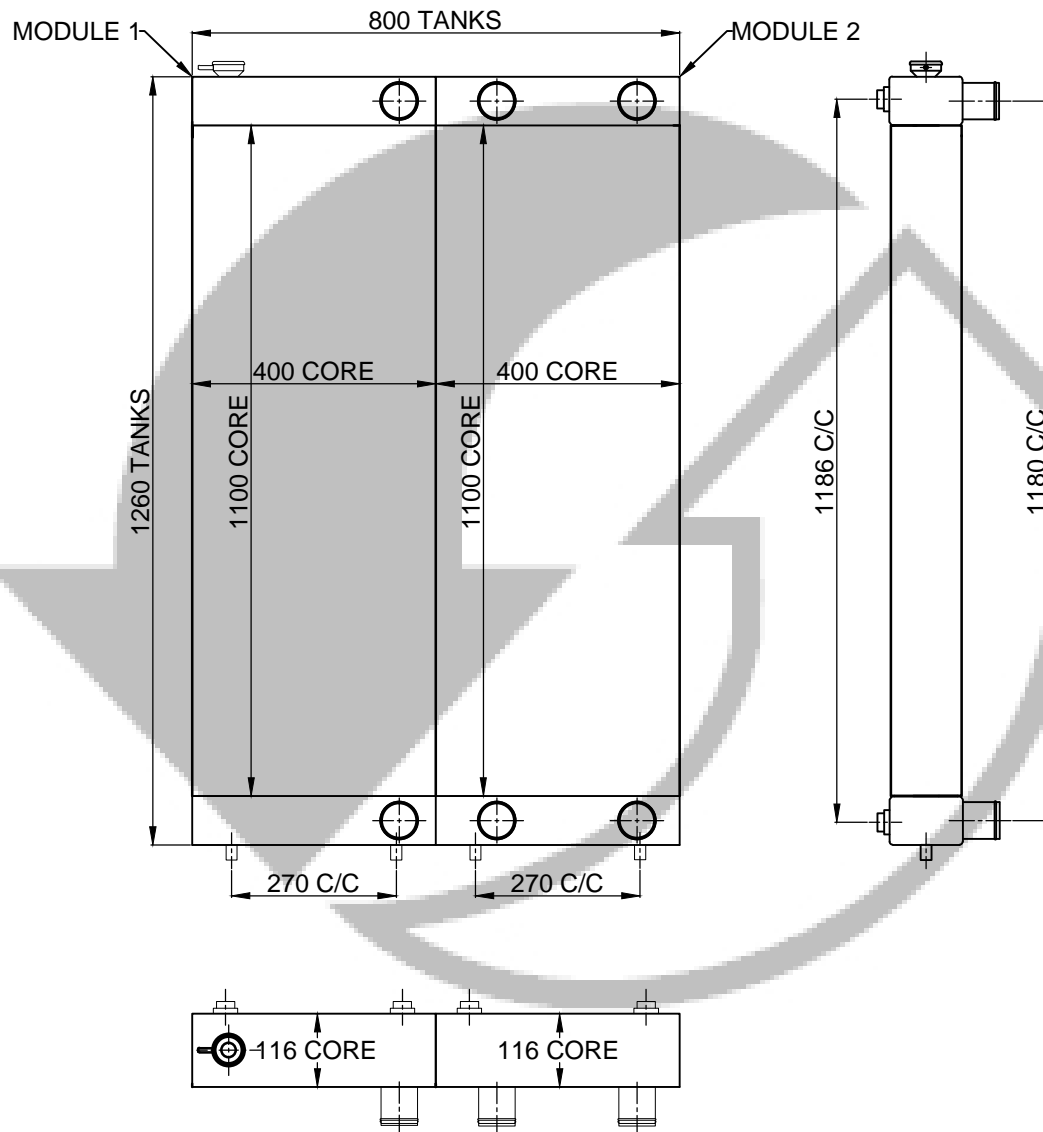

MODEL:HITACHI ZX680

PART NUMBER:RAD1100HIT1COM

RADIATOR-HITACHI

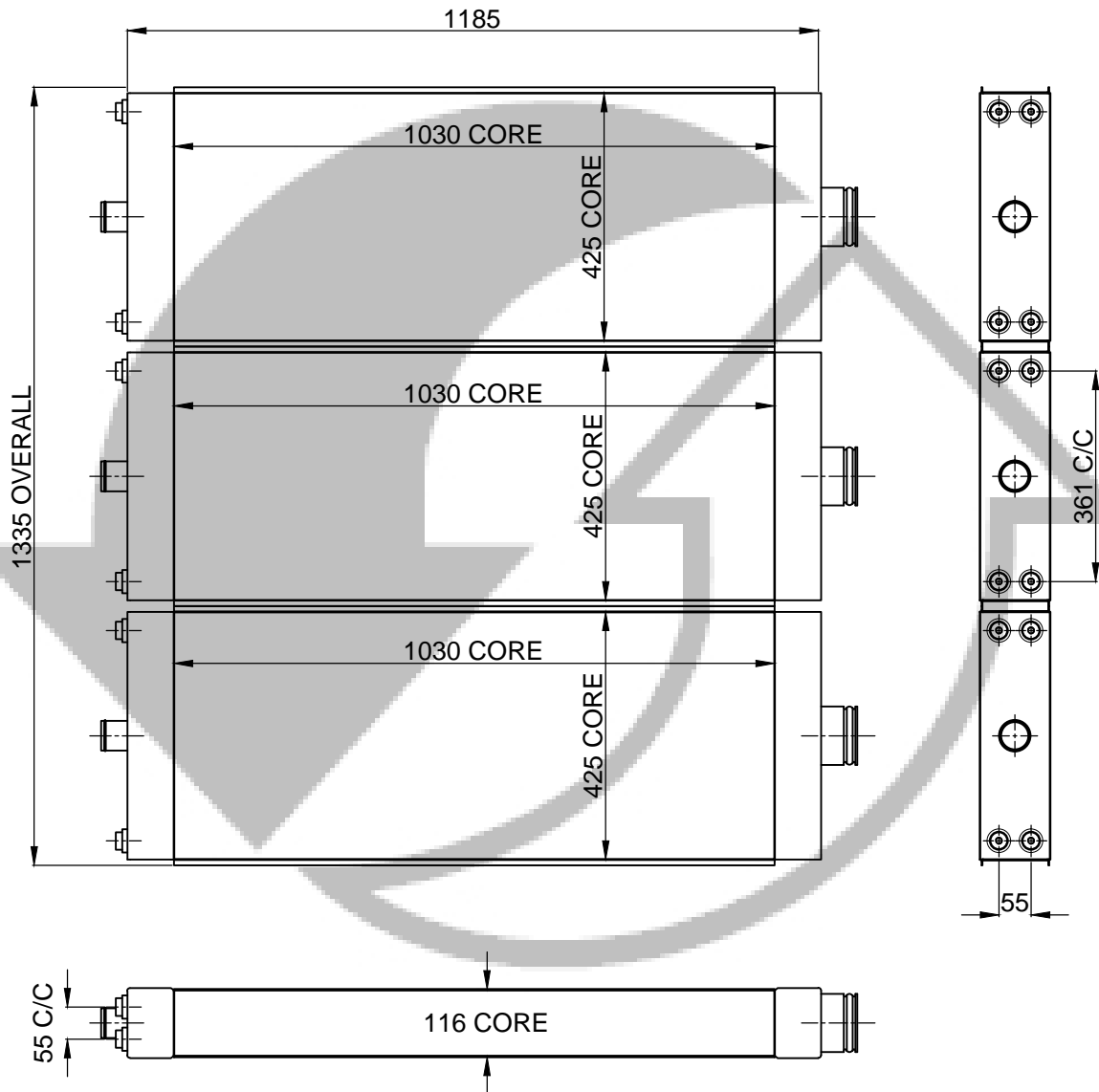

MODEL:HITACHI ZX870

PART NUMBER:RAD1030HIT1COM

RADIATOR-INTERNATIONAL

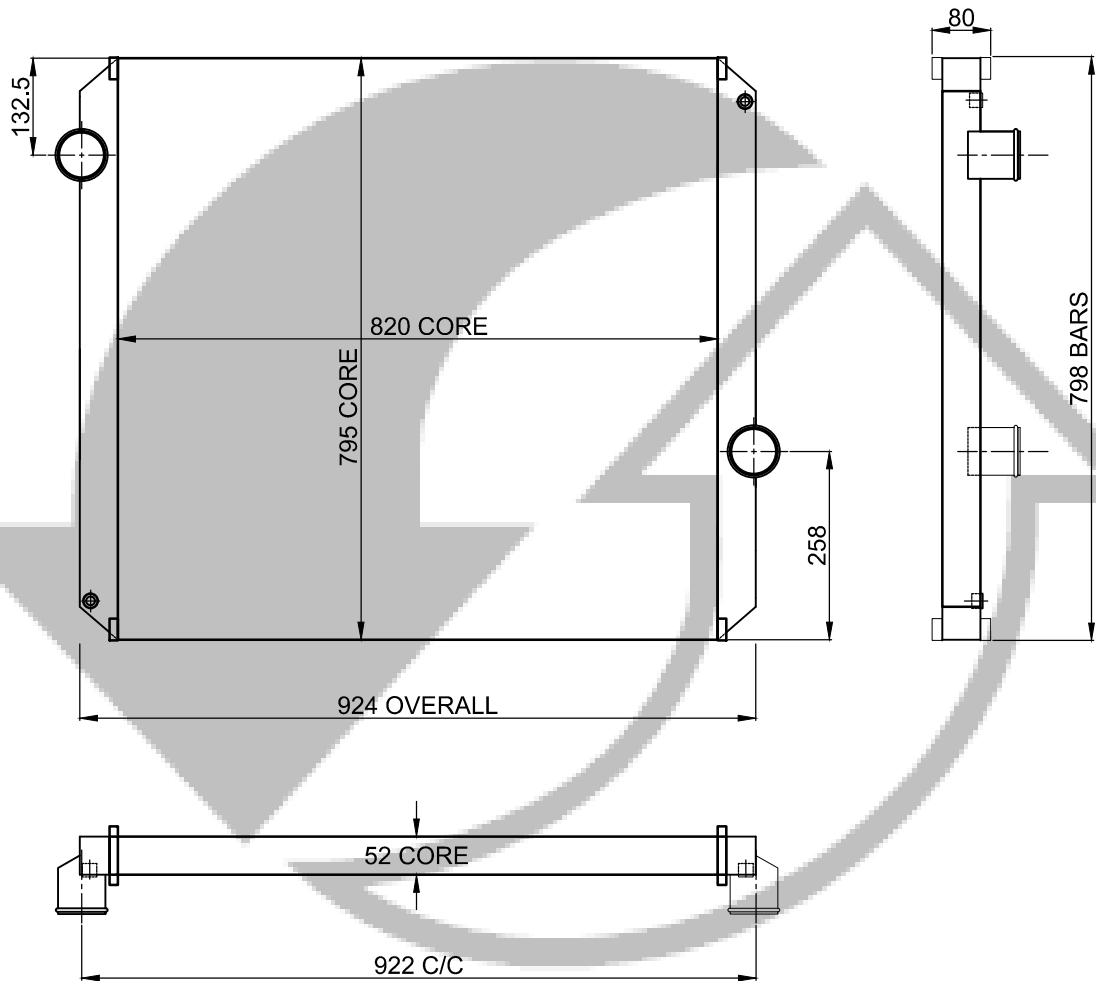

MODEL:INTERNATIONAL EAGLE 9800i

PART NUMBER:RAD820INT1COM

RADIATOR-ISUZU

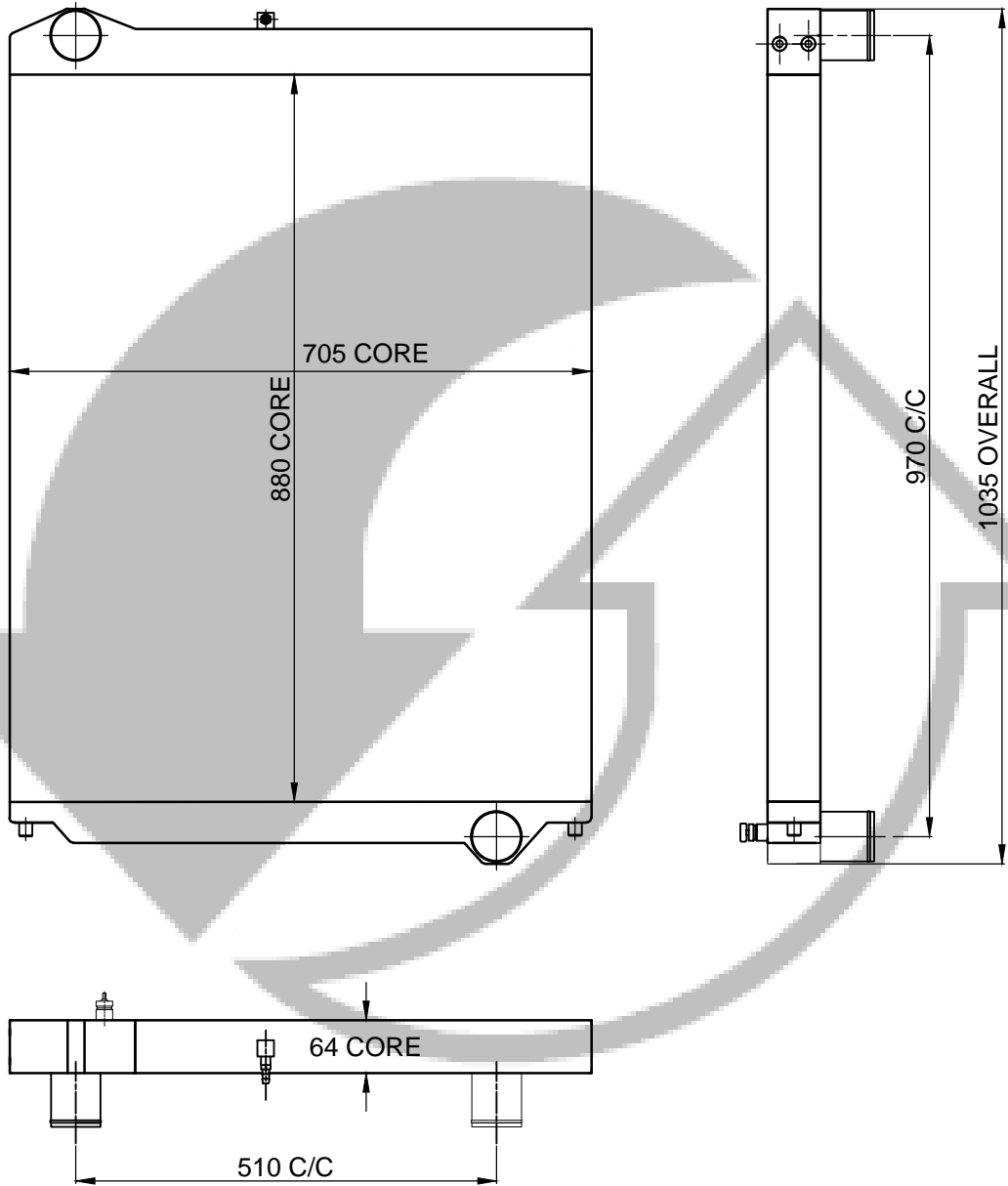

MODEL:ISUZU FXZ

PART NUMBER:RAD880ISU1COM

RADIATOR-KOMATSU

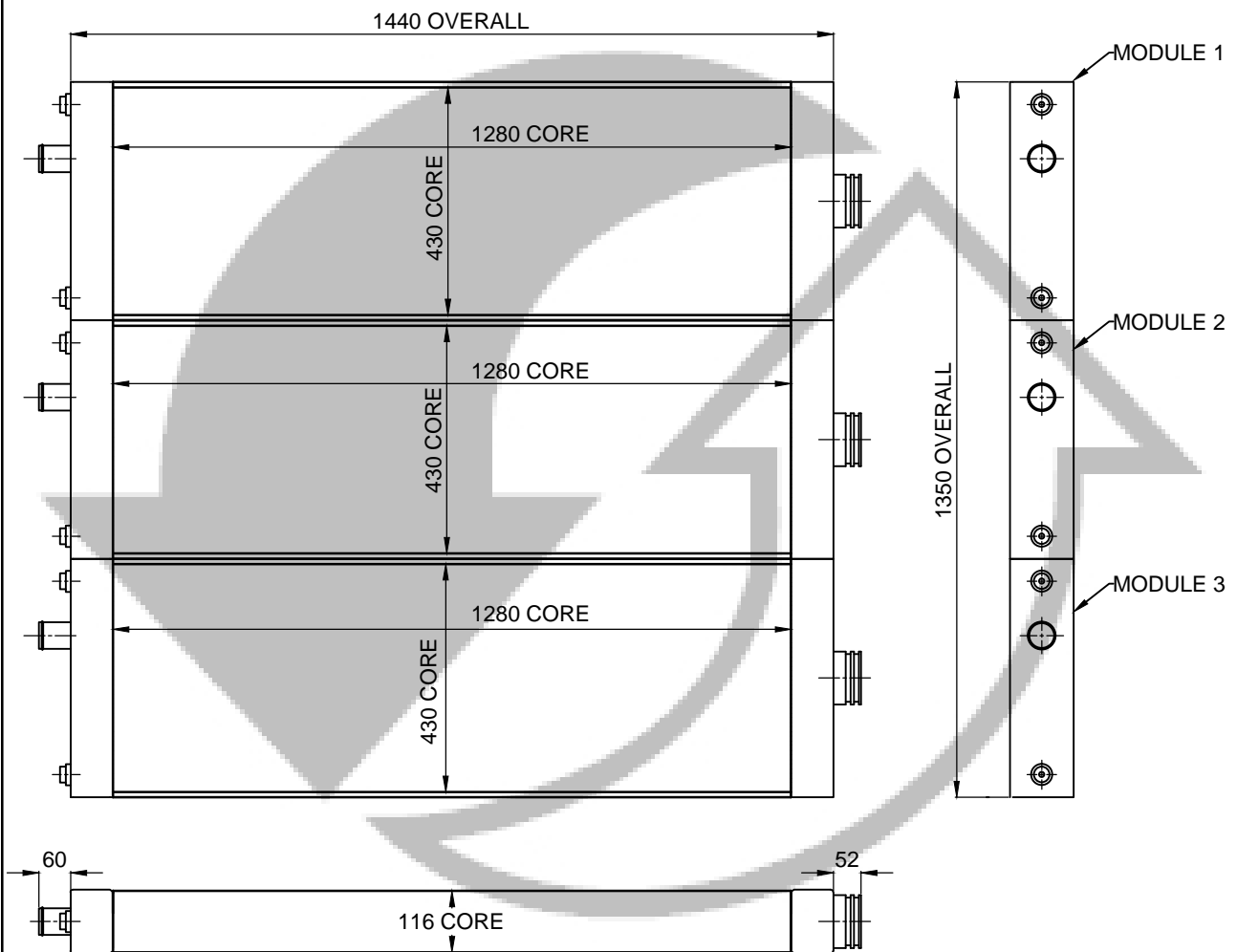

MODEL:KOMATSU D375

PART NUMBER:RAD1280KOM1COM

RADIATOR-KOMATSU

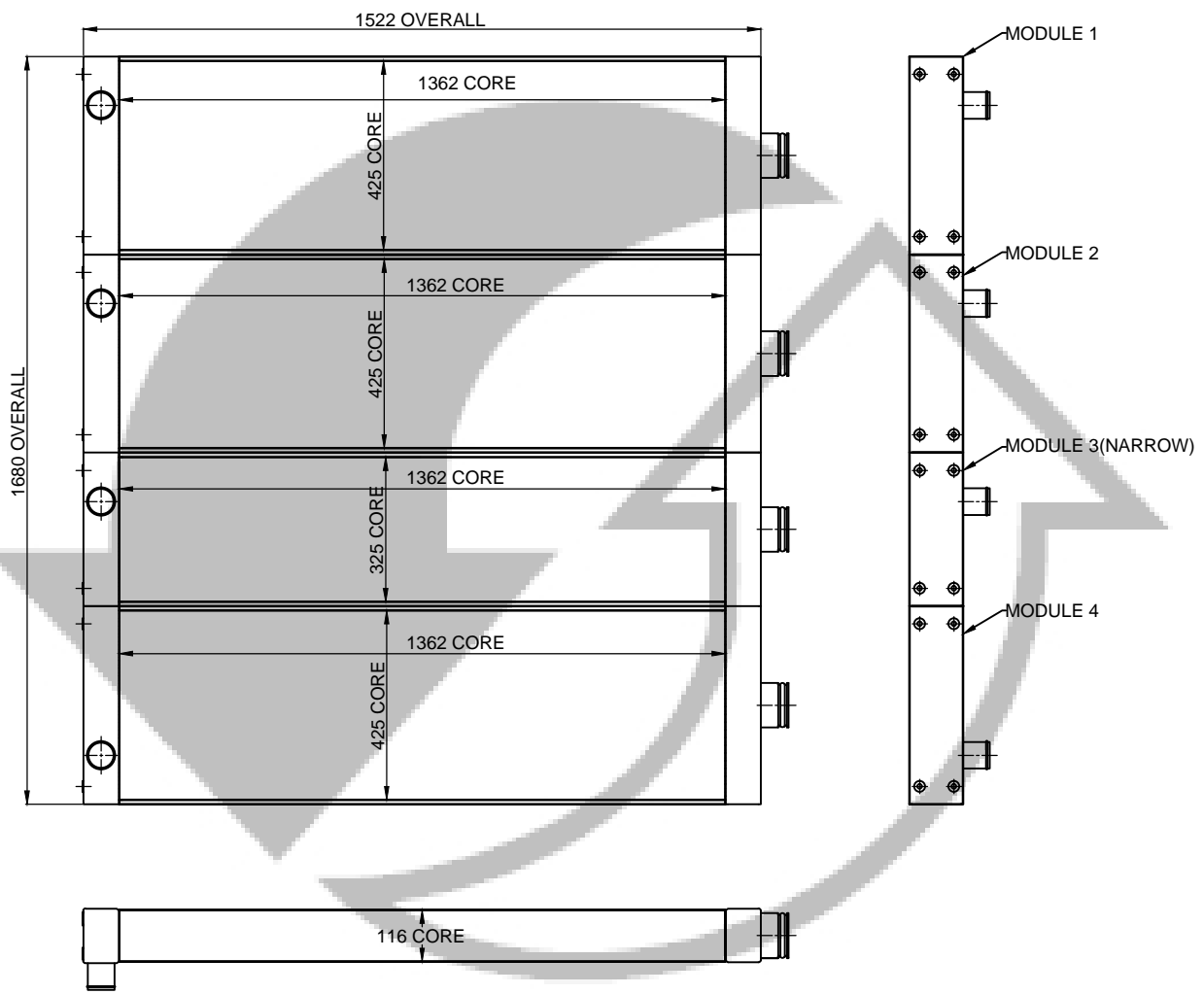

MODEL:KOMATSU D785

PART NUMBER:RAD1362KOM1COM

RADIATOR-MAN

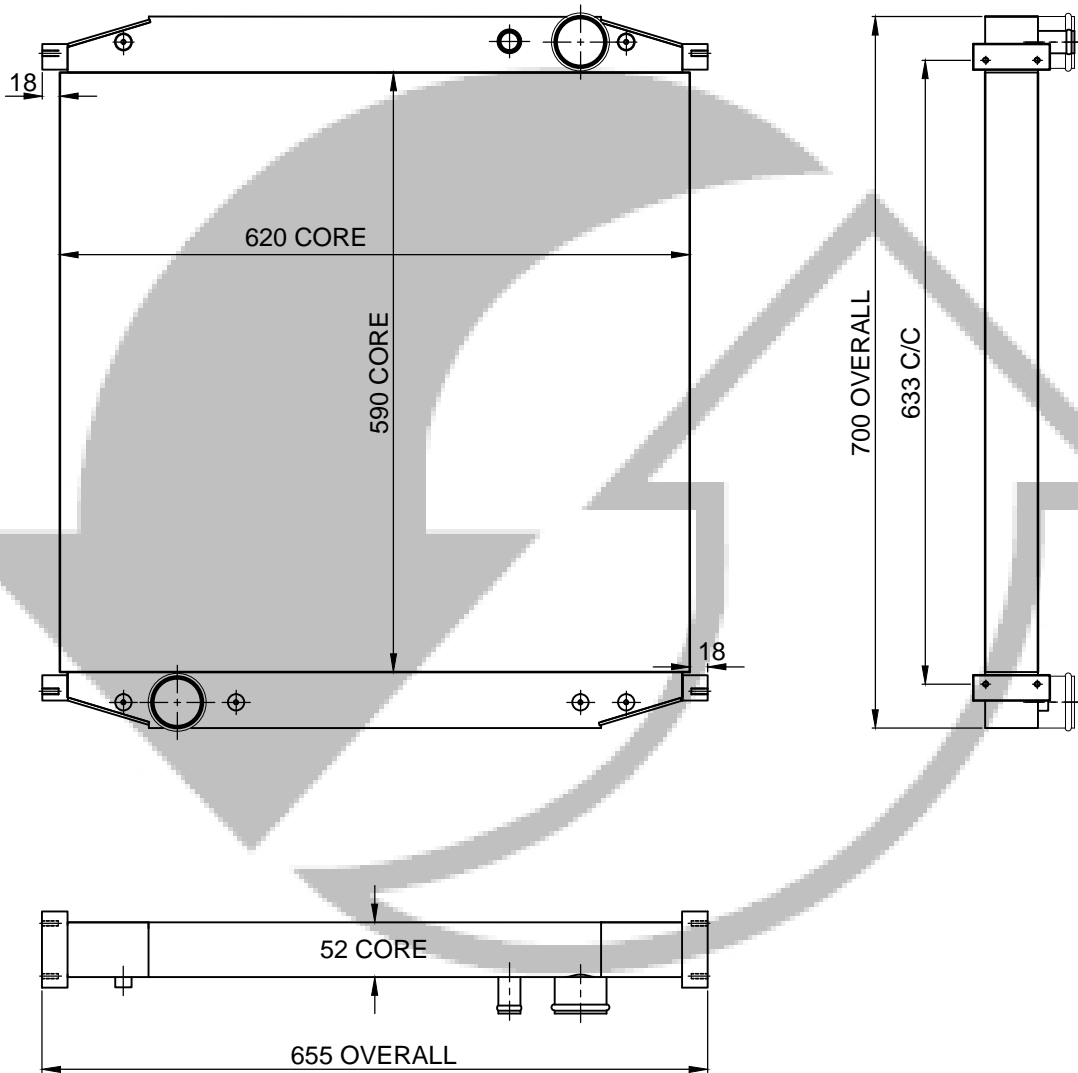

MODEL:590 MAN CLA RANGE V1

PART NUMBER:RAD590MAN1COM

RADIATOR-MAN

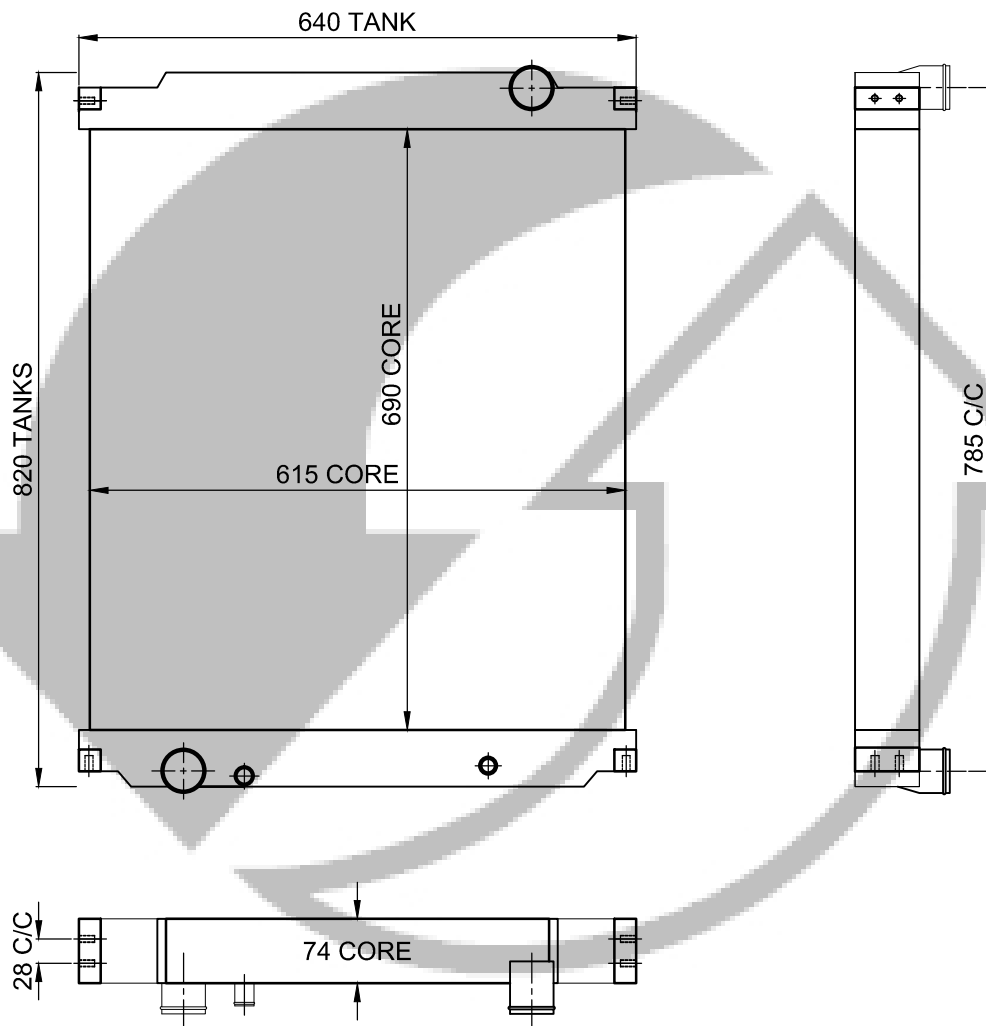

MODEL:690 MAN CLA V2

PART NUMBER:RAD690MAN1COM

RADIATOR-MAN

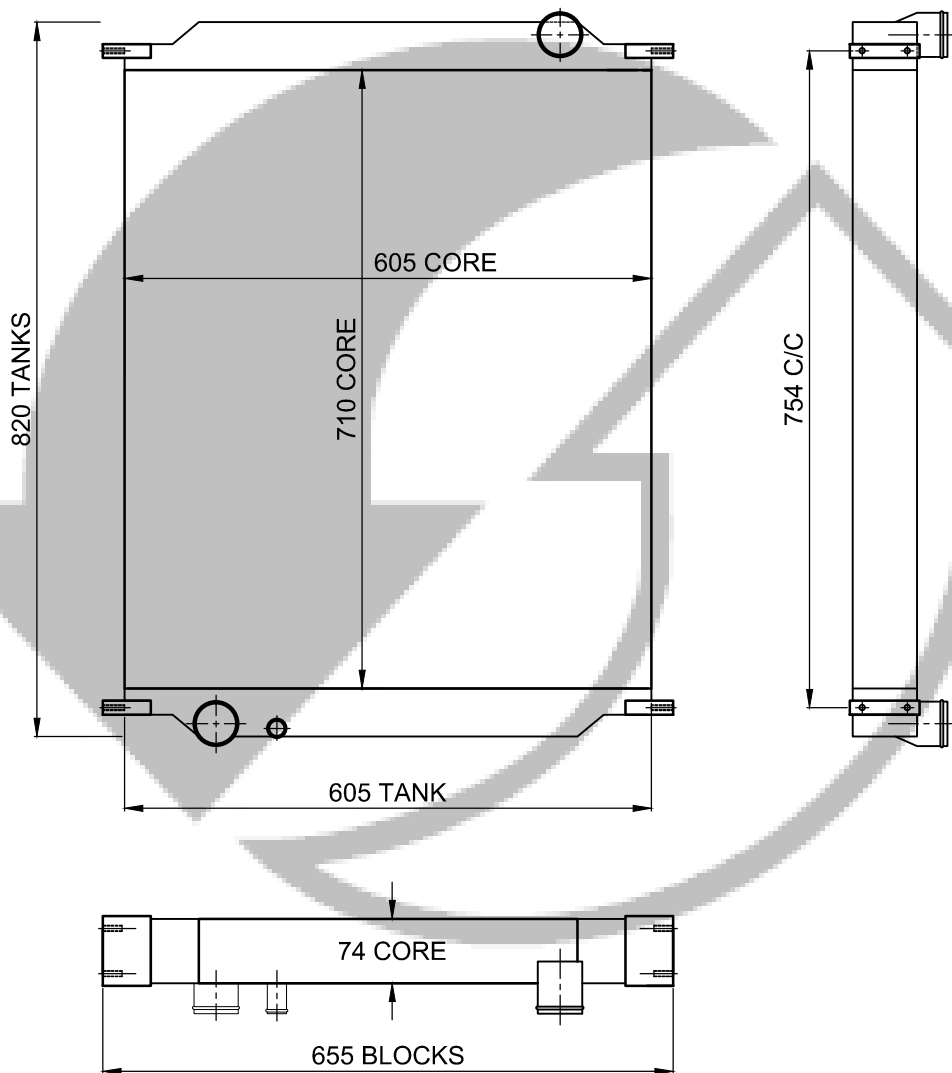

MODEL:710 MAN LE280 TGM RANGE

PART NUMBER:RAD710MAN1COM

RADIATOR-MORGAN

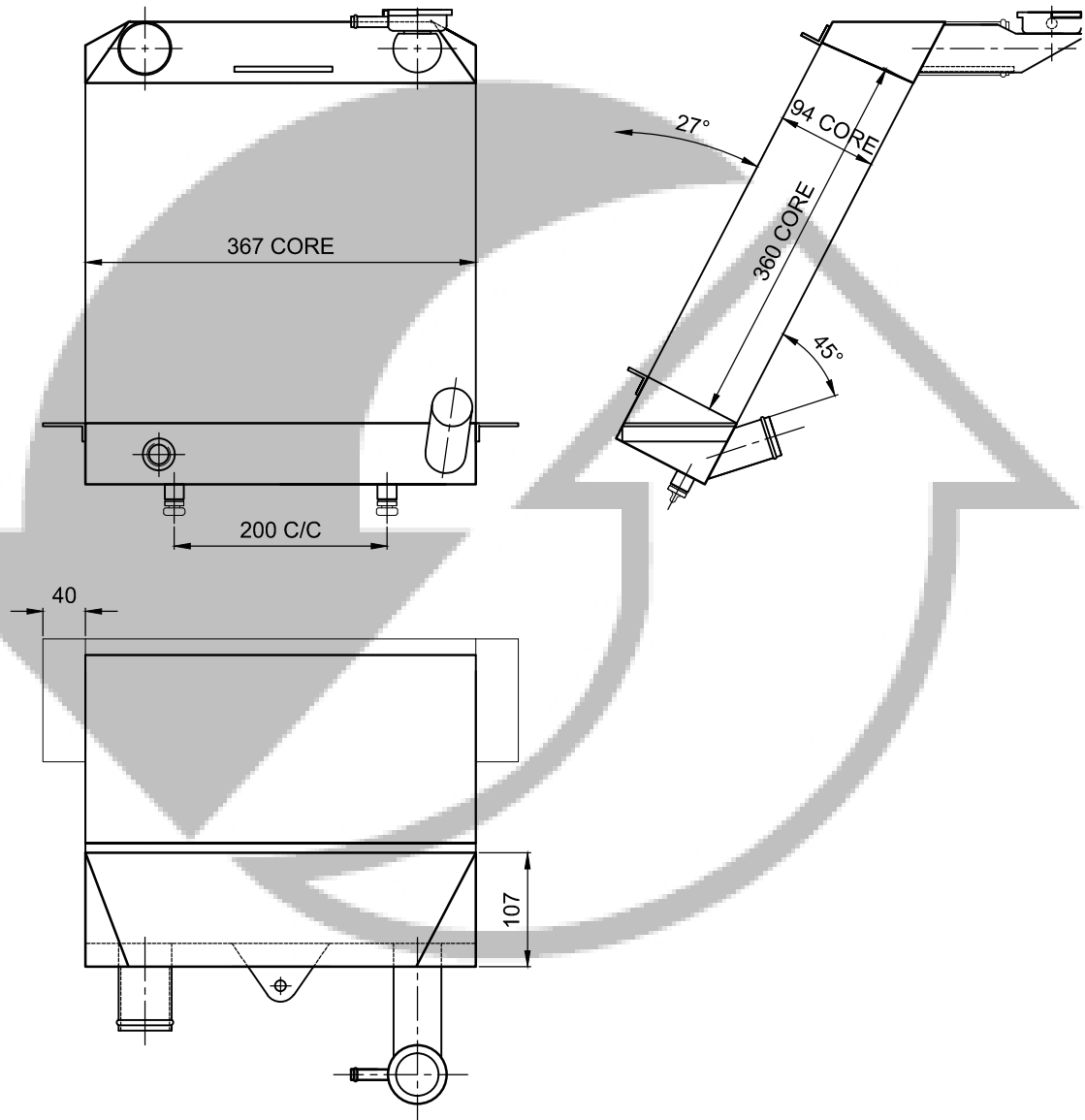

MODEL:MORGAN PLUS 8

PART NUMBER:RAD360MOR1COM

RADIATOR-NISSAN

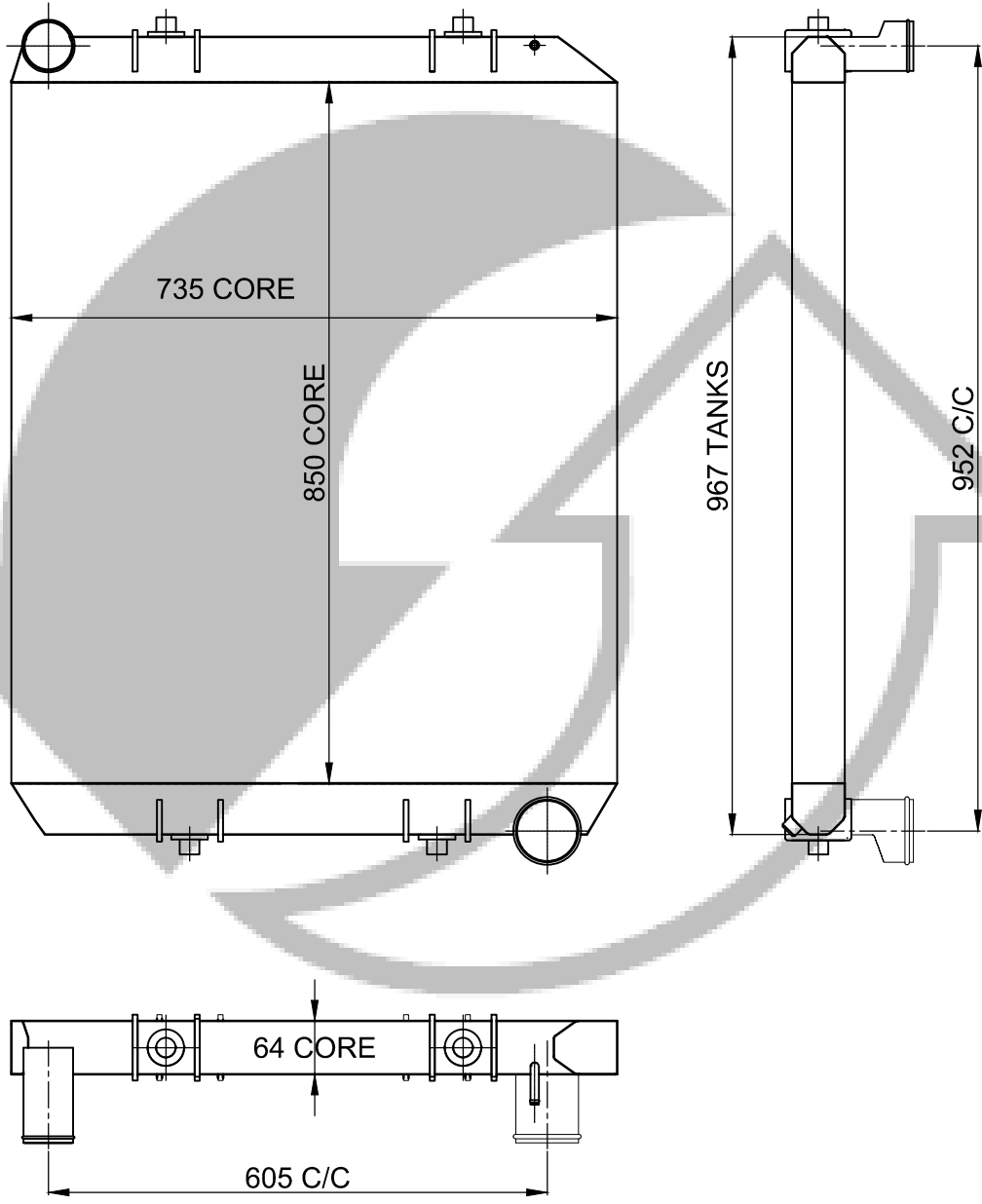

MODEL:NISSAN UD 370

PART NUMBER:RAD850NIS1COM

RADIATOR-NISSAN

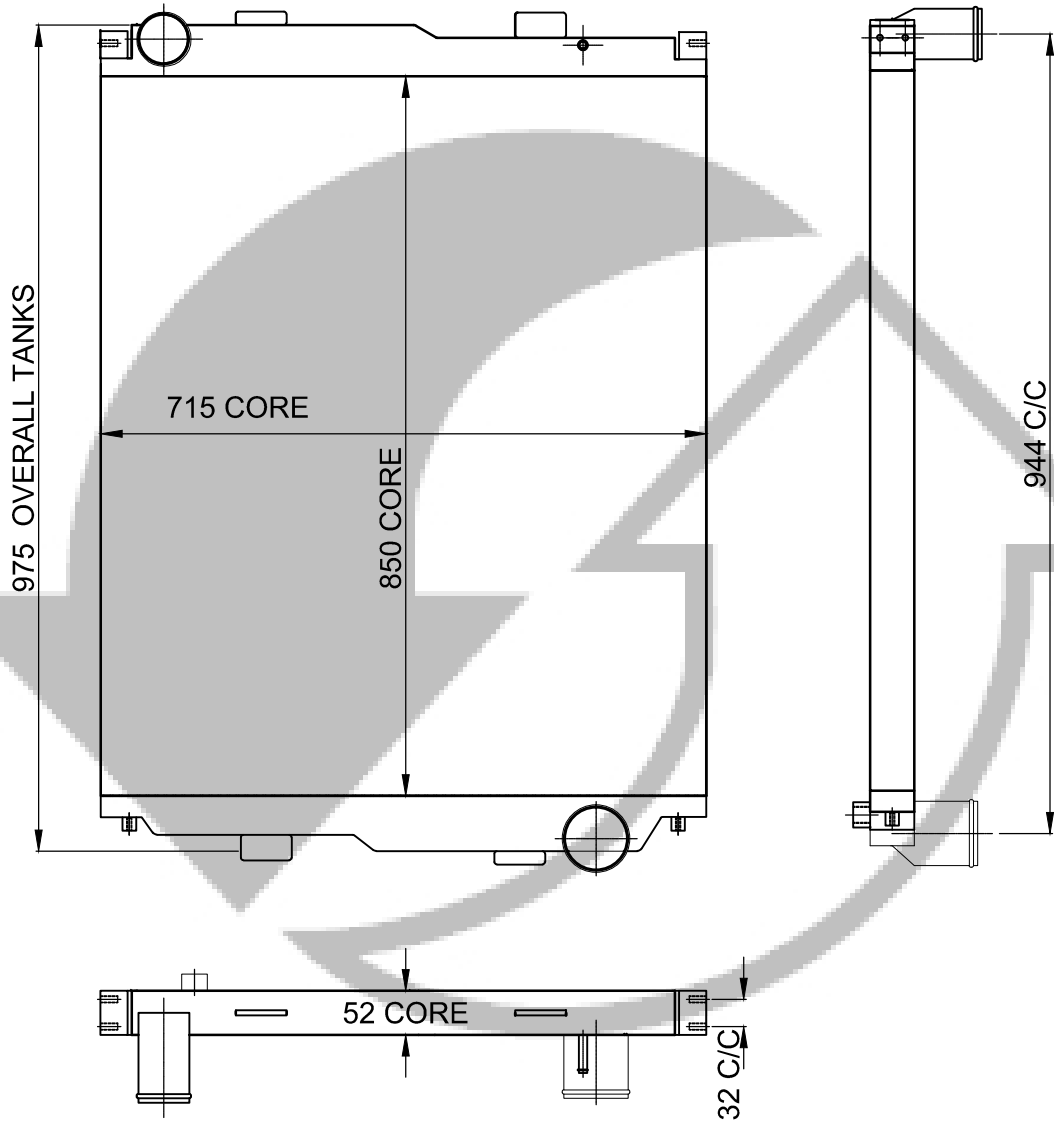

MODEL:NISSAN UD440

PART NUMBER:RAD850NIS1COM

RADIATOR-VOLVO

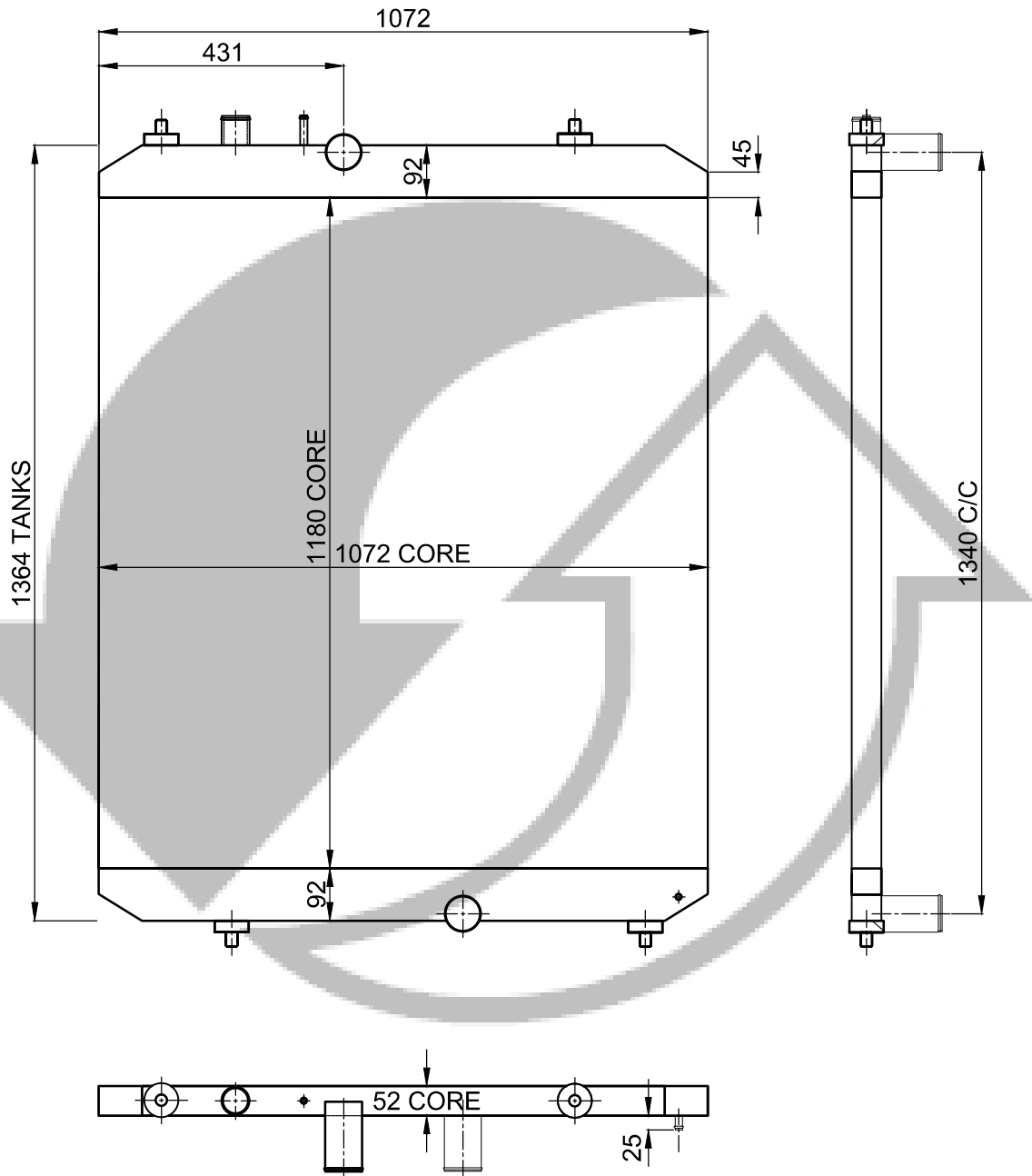

ALSO AVAILABLE IN COPPER



MODEL:VOLVO PENTA TAD1641GE

PART NUMBER:RAD1180VOL1COM

RADIATOR-VOLVO

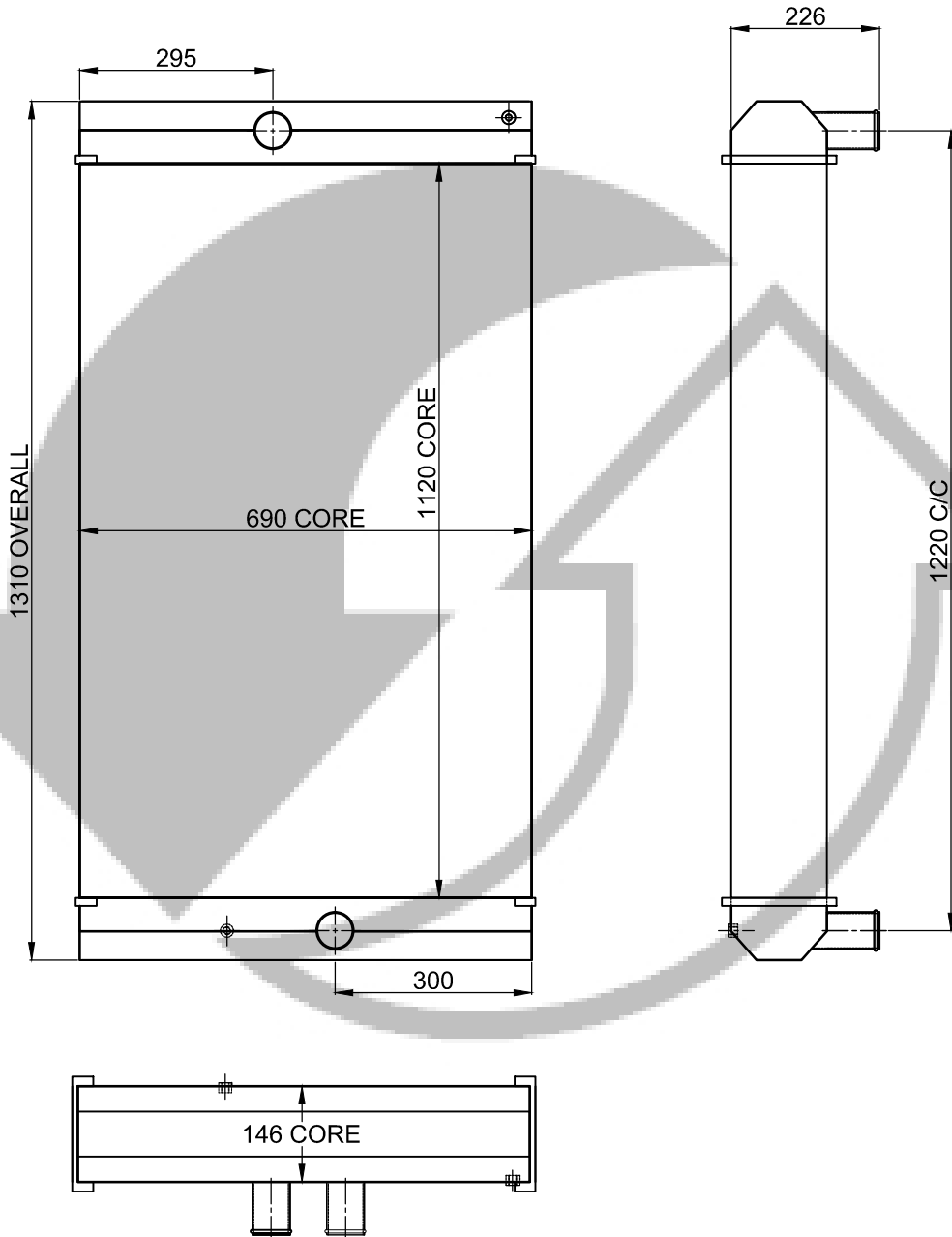

MODEL:VOLVO EC750

PART NUMBER:RAD1120VOL1COM

RADIATOR-SWIMMING POOL

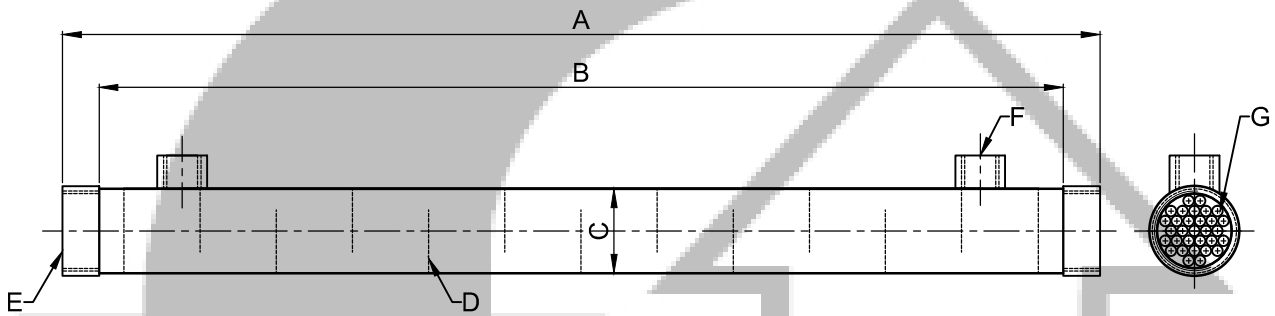

Model	A	B	C	D	E	F	G
5 KW	464	420	Ø50.8	7	1½" BSP	½" BSP	Ø6
10 KW	624	580	Ø50.8	11	1½" BSP	½" BSP	Ø6
15 KW	794	750	Ø50.8	15	1½" BSP	½" BSP	Ø6



MODEL:SWIMMING POOL COOLER

PART NUMBER: SP5 TO SP15

INTERCOOLERS

INTERCOOLER-BELL

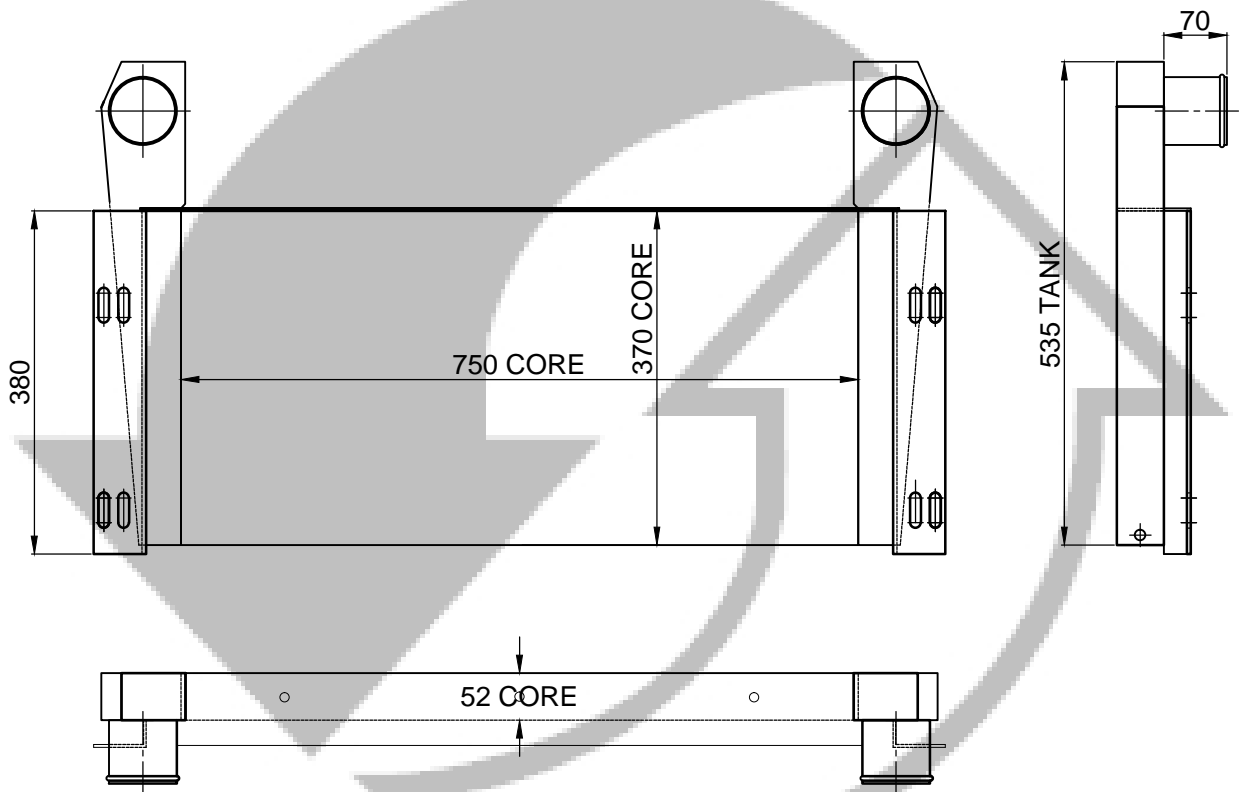

MODEL: BELL_KARMAZON

PART NUMBER: INT750BEL1COM

INTERCOOLER-FORD

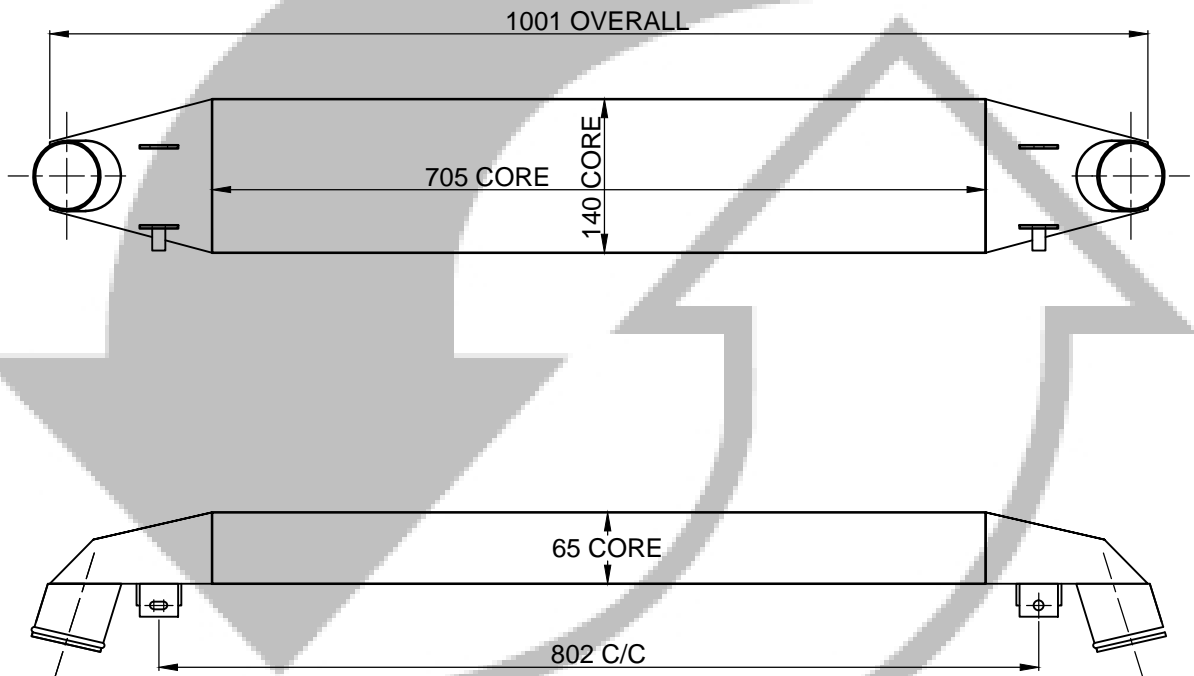

MODEL:FORD FIESTA ST

PART NUMBER:INT705FOR1COM

INTERCOOLER-FORD

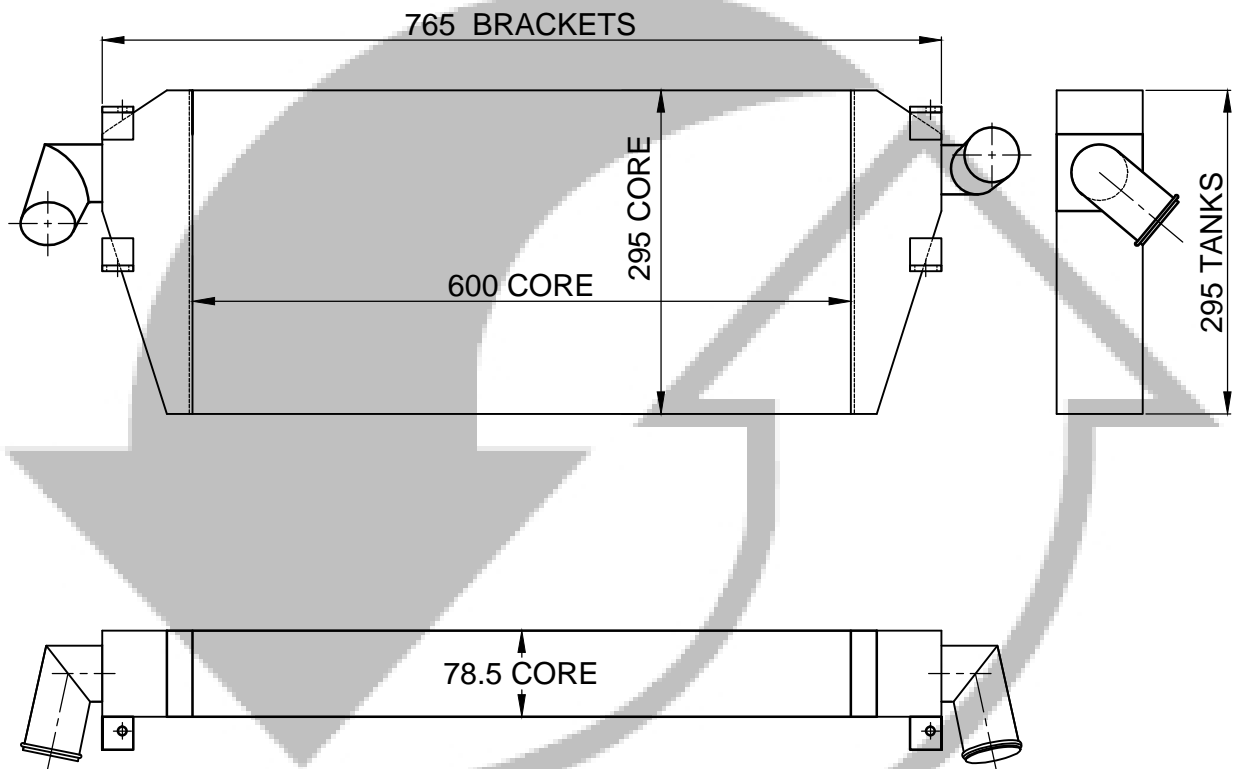

INTERCOOLER-ISUZU

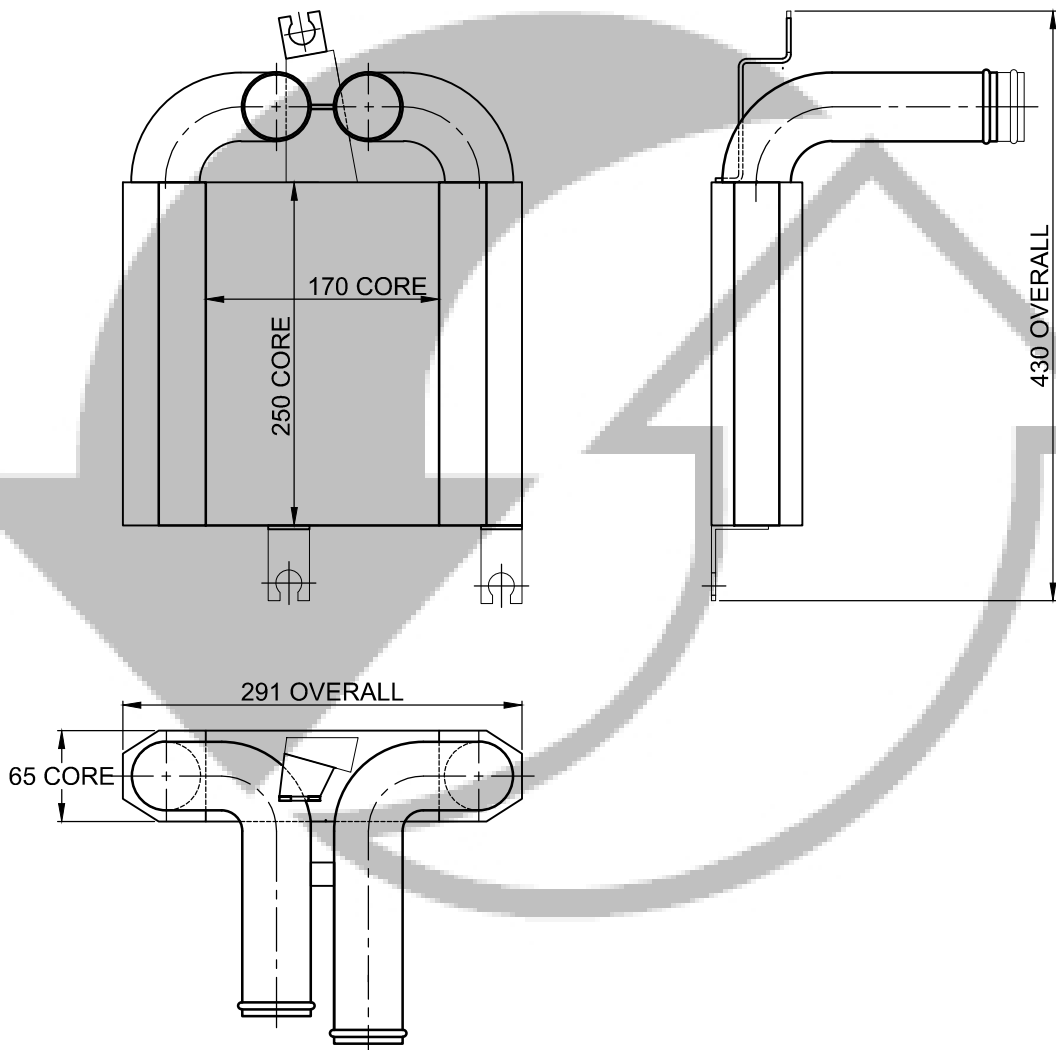

MODEL:ISUZU KB300

PART NUMBER:INT170ISU1COM

INTERCOOLER-ISUZU

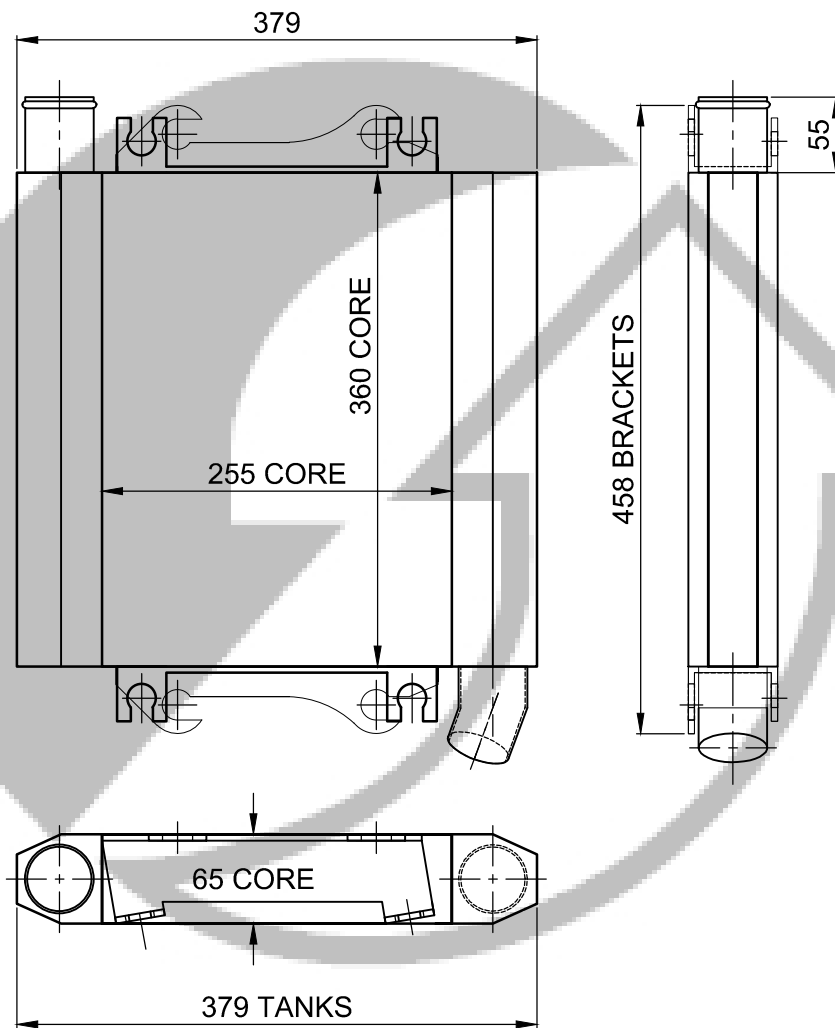

MODEL: ISUZU D-TEQ

PART NUMBER: INT255ISU1COM

INTERCOOLER-LAND ROVER

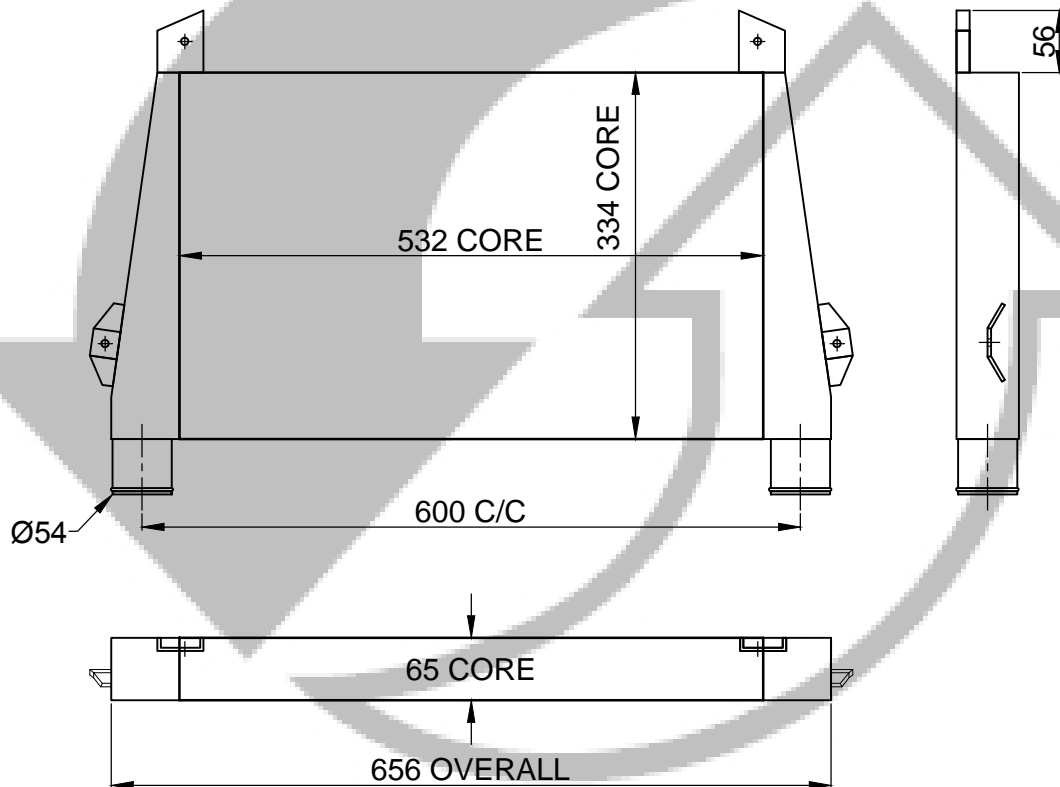

MODEL:LAND ROVER TDV6

PART NUMBER:OIL532LAN1COM

INTERCOOLER-LAND ROVER

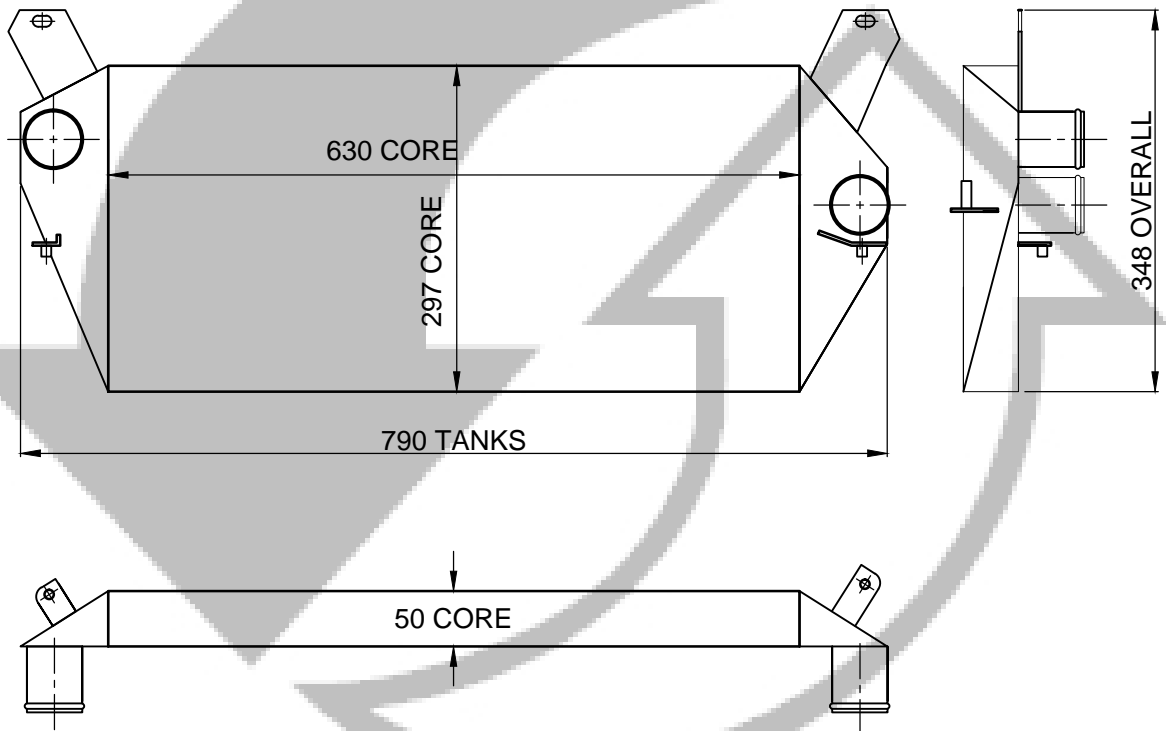

MODEL:LAND ROVER DISCOVERY TD5

PART NUMBER:INT630LAN1COM

INTERCOOLER-MINI

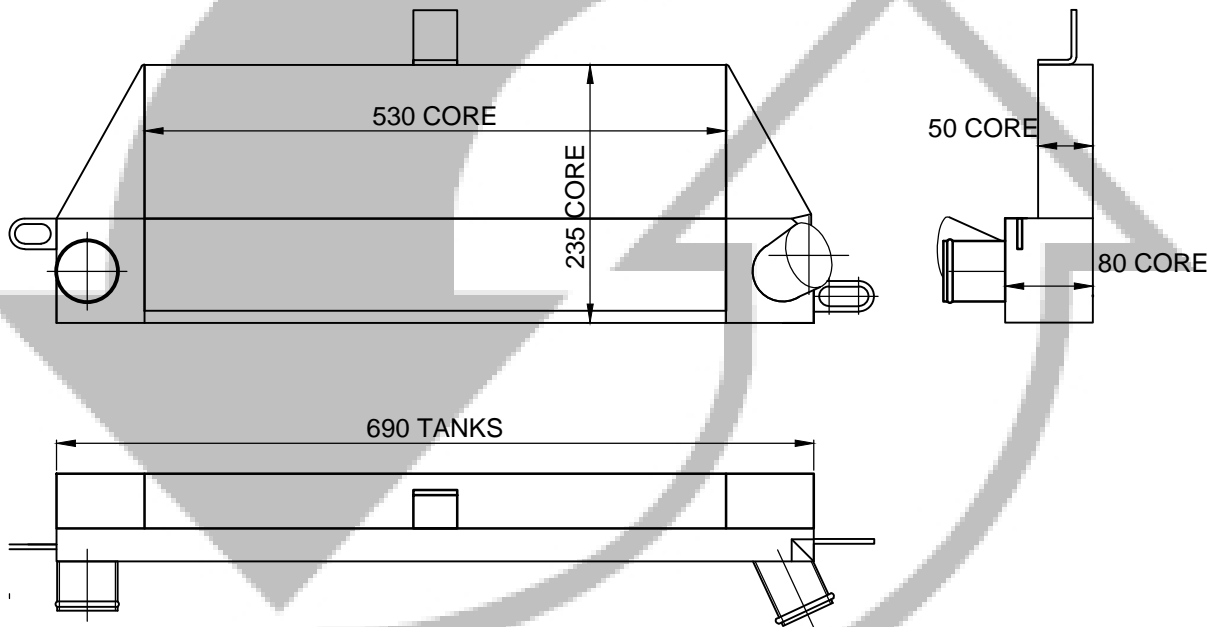

MODEL:MINI COOPER S

PART NUMBER:INT530MIN1COM

INTERCOOLER-TOYOTA

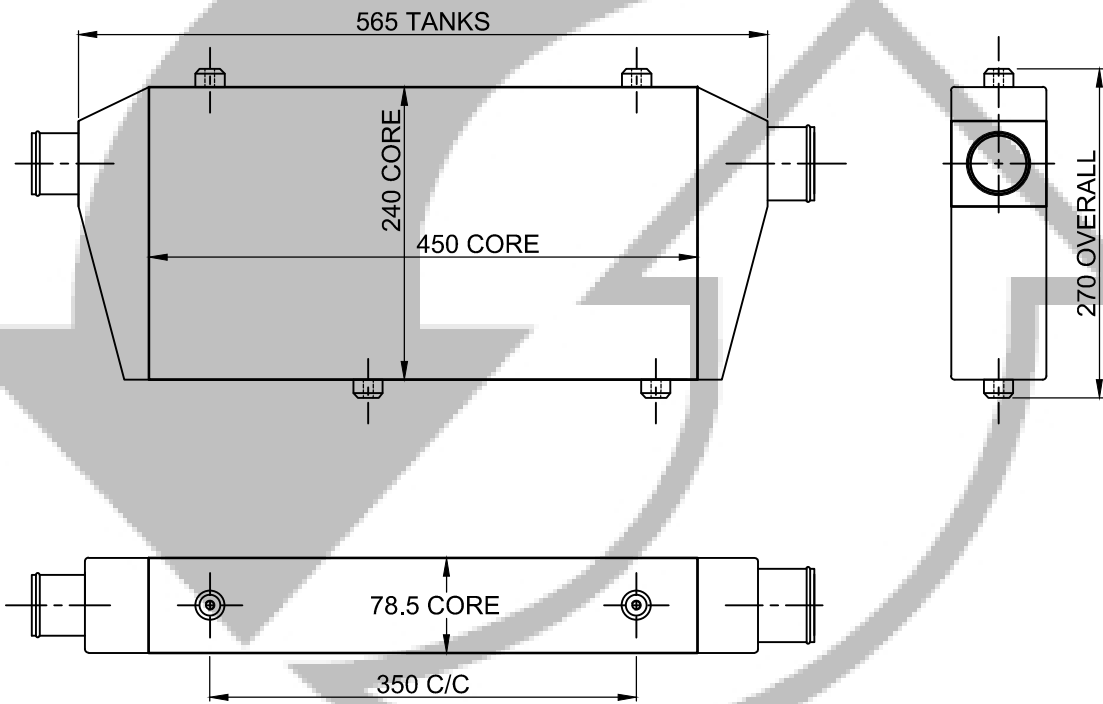

MODEL: TOYOTA HILUX D4D

PART NUMBER: INT450TOY1COM